

Canadian Rail



Number 166 / May 1965



Independent days of the Orford Mountain Railway
are recalled by this pastoral scene
showing the wayfreight switching at Lawrenceville
about year 1905.

(Collection O.S.A.Lavallée)

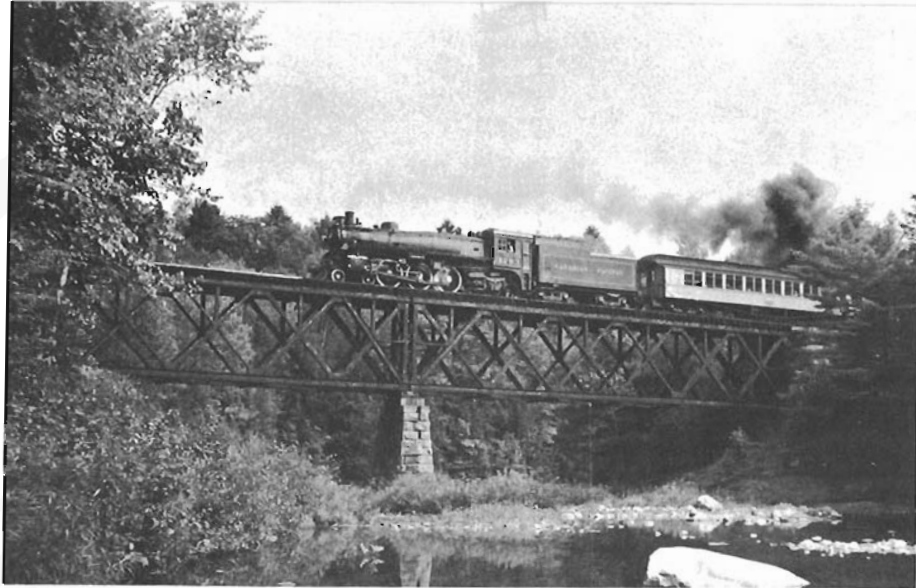

Steam power bearing the "Canadian Pacific" insignia is not entirely dead. At least one locomotive of the C.P.R. 1200 class is in operating condition and performs service over part of the former Rutland Ry in Vermont, U.S.A. The engine, #1293, now the property of the Monadnock Northern, was used on the M.N.'s excursion trains between Riverside (Bellows Falls) and Chester, Vt., during the latter part of the 1964 season. The above photograph shows the locomotive crossing one of the scenic bridges near Rockingham on September 19th, 1964.

(D.S.Robinson)

The picture below shows Canadian Pacific 3651, which is now on permanent display at Lethbridge, Alberta. It is located in Galt Gardens, a park in the downtown section of the city, a short distance from the railway station.

(D.W.Brow)

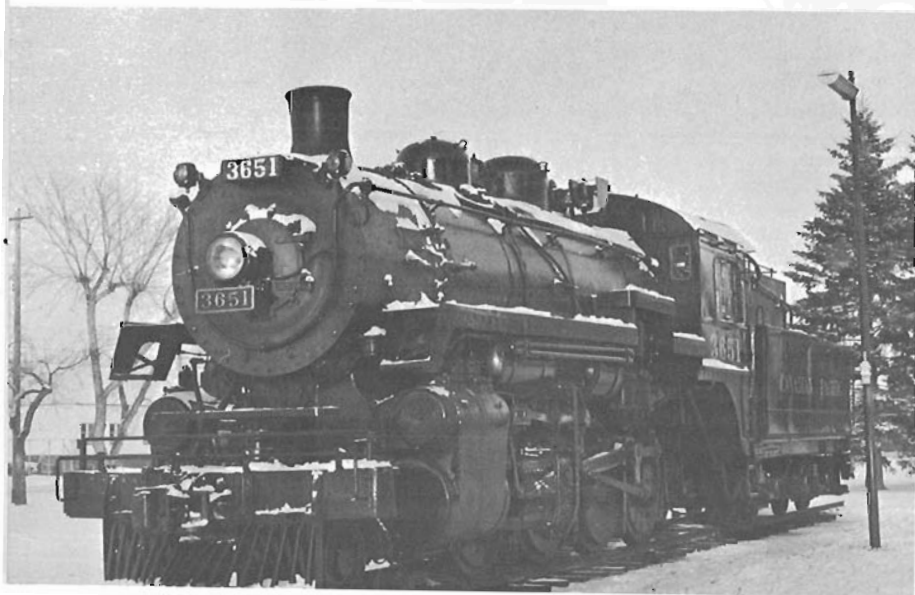

Valedictory for the Orford Mountain



IN RESPONSE to a recent application by Canadian Pacific Railway Company, the Board of Transport Commissioners for Canada has authorized the railway to abandon most of its Orford Subdivision in the Province of Quebec, extending from Eastman to Valcourt, 13.9 miles. This abandonment, to take effect on April 30th next, marks the closing of the last existing section of the former Orford Mountain Railway Company, a process which has taken just a few weeks over twenty-nine years. Though the history of the Orford Mountain was summarized in a sketch prepared by the late Robert R. Brown for the CRHA News Report in 1952, and reprinted in the October 1964 issue of "Canadian Rail" at page 221, it would now seem appropriate to review the interesting history of the OMR in more detail, and in the light of additional facts since uncovered.

Early Copper Mining

The story begins somewhat over a century ago when the demand for copper brought about by the civil war in the United States encouraged interests headed by L.S. Huntingdon to exploit a mine near Dillonton, about three miles south of the present village of Eastman, Que.; the site was later known as Bolton Mines. The war economy forced copper prices up from 28 to 55 cents a pound, and by 1862, the Huntingdon mine employed several hundred men, the ore being transported by wagons for about twelve miles to the railhead of the Stanstead, Shefford & Chambly Railway at Waterloo. The demand for this mineral held up following the conclusion of hostilities in 1865, and other similar deposits in the same general area were opened up and worked, among them a mine near South Durham whose proprietors included the name of Jefferson Davis; the former President of the Confederate States of America had fled to Montreal with his family for asylum, following defeat of the Confederacy in 1865.

In 1870, Huntingdon sought and obtained a charter for a light mining tramway to connect the Dillonton mine with Waterloo. Partly due to a falling off in copper demand, however, the tramway was never completed, though there is said to be evidence of a roadbed in the vicinity of Libby Pond. The tramway's rights were sold to Central Vermont Railway interests on July 26, 1871 and were eventually transferred, in 1874, to the Waterloo & Magog Railway which had been incorporated on December 13, 1871, and was then under construction between the towns in its corporate title.

The First Railway

In 1870, the Missisquoi & Black Rivers Valley Railway Company was chartered to build from Potton, south of Bolton Mines, to, at or near Durham or Richmond on the Grand Trunk Railway. This was the first charter issued covering territory later served by the Orford Mountain Railway. In the ensuing years, the company constructed the railway grade between Melbourne (near Richmond) and Potton Springs and, after the completion of the Waterloo & Magog to Bolton Forest (Eastman) in 1877 enabled construction material to be brought in by rail, the M&BRVry. laid track on its own grade from Bolton Forest to South Bolton, 10.1 miles. This line was then operated by the Waterloo & Magog for the proprietors of the Missisquoi & Black Rivers Valley Railway until about 1887, when service was suspended due to the W&M being sold to Canadian Pacific Railway interests. The M&BRV owned no rolling stock.

Orford Mountain Railway

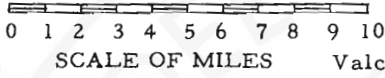

The Second Railway

In 1888, a new body, the Orford Mountain Railway Company was granted a charter to build from Eastman to Lawrenceville and elsewhere. Since this charter covered territory previously included in the Missisquoi railway charter, it is evident that the latter's rights of extension had lapsed. Construction got under way in 1891, using the old Missisquoi grade; by the summer of 1894, it was in operation between Eastman and Kingsbury, 26.5 miles. Inauguration of service on the Orford Mountain resulted in partial resuscitation of the completed section of the Missisquoi railway which had been abandoned in 1887. At this time, 7.34 miles of the M&BRV Ry. are shown¹ as "operated in summer by the Orford Mountain Railway, for freight only, between Eastman and Bolton Centre"; the rails extended a further 4.6 miles to a point south of Potton Springs, but the same source listed this as "disused".

In the decade following completion of its initial section, the Orford Mountain Railway enjoyed successful operation, and turned a modest profit. Its principal traffic was lumber which accounted, in the eleven year period ending in 1904, for a total of well over one-third of the total freight tonnage, or an average of more than eight million board feet a year. Other forest products such as firewood and pulp wood helped this category to account for about one half of all traffic. The railway was well managed, the ratio of earnings to working expenses in the same (1894-1904) period averaging 112:100. The officers at this time included S.W. Foster, President, Knowlton, Que.; G. Stevens, Secretary & Treasurer, Waterloo, Que.; A.C. Lytle, Superintendent, Eastman, Que.

In 1904, the decision was made to effect certain extensions:

- (1) From Kingsbury to Windsor Mills, on the St. Francis River, completed in 1905.
- (2) From Eastman to Bonallie (Stukely) Lake, completed in 1906, and
- (3) An extension of the former Missisquoi line, from Potton Springs to Mansonville, built in 1906 and opened on July 12th, 1907.

This expansion policy proved to be ill-advised; while additional traffic was generated, operating costs of the extended system rose out of proportion, and by the end of 1906, the earnings/working expenses ratio had exactly reversed itself to 88:100. The consequent loss of public confidence enabled the Canadian Pacific Railway, then in an expansionist phase, to purchase all of the capital stock at bargain prices, and on March 7th, 1910, by an Order-in-Council, the Orford Mountain Railway was leased to the Canadian Pacific for 999 years, integrated into the larger system as the Orford Subdivision.

Under C.P.R. Control

The new owners took the obvious step immediately and in 1910 and 1911, built an additional 4½ miles of track southward from Mansonville and over the border into Vermont, there to connect with the Newport and Montreal main line at a point six-tenths of a mile east of North Troy, called Troy Junction. The mile of track on the Vermont side was built under the charter of the Midland Railway of Vermont. While it may be questioned whether the acquisition of the Orford Mountain was a good capital investment for the CP, it might well have been justified on the basis of "insurance" alone, as the Mansonville end of the independent line was only about fifteen miles distant from Richford, Vermont and the Central Vermont system, which had occasionally evinced interest in the Canadian short line. Failure of the CP to take action might have

provided the CV with a ready-made feeder deep into Canada and Canadian Pacific "territory". The erstwhile Orford Mountain Railway had now reached its greatest extent.

The first contraction of mileage came about shortly after the commencement of the first World War, when the branch into Bonallie Lake was ripped up for use elsewhere during the war shortage.

Under CPR operation, the Orford Subdivision enjoyed four passenger trains daily, two in each direction. Train #270 left Windsor Mills in the morning for North Troy, returning in the afternoon as #273. Also in the morning, #271 left North Troy for Windsor Mills, returning in the afternoon as #272. All trains crossed at Eastman where there was a three-hour layover for connections, the trains going up the 1.4-mile spur to Eastray to meet Montreal-Sherbrooke-Saint John main line services. By the Twenties, the service had diminished to one round trip a day, #276 southward from Windsor Mills, returning from North Troy as #275.

Contraction

On April 1st, 1936, the 22.8 miles of track between Troy Junction (by now called Elkhurst) and Eastman was abandoned, and fifteen miles of track from Elkhurst to Bolton Centre removed in that year; the balance remained in place until the demand for war scrap claimed it in 1942. At the other end of the system, the Kingsbury-Windsor Mills portion lost its train service on April 27th, 1940, and was officially abandoned on December 23rd, 1941. Its 9.4 miles of rails were also removed in 1942.

The next abandonment took place in the period of economic "retrenchment" following the end of World War II, and this was the 12.7-mile portion from Valcourt to Kingsbury, whose service was abandoned on December 15, 1949, the rails being lifted in 1950. The station at Flodden, on this section, was removed and transplanted to the Montreal lakeshore suburban area, as a shelter was needed at Grovehill. Still lettered "Flodden", it was unloaded from a flatcar and for a few days while awaiting repainting, it aroused the ire of at least one local commuter of Caledonian ancestry, who thought it high-handed of the CPR to rename "his" station after the spot in northern England where the Scots went down to honourable but crushing defeat at the hands of the English in 1513. Flodden, alias Grovehill, remained in use for a decade.

Following the 1949 abandonment, the former Orford Mountain Railway was reduced to a meagre 13.9 miles, extending from Valcourt to Eastman. This may have disappeared at this time as well, but for traffic which in large measure originated from the well-known Bombardier snowmobile factory at Valcourt, which community was served until recent years by execrable roads. The inevitable extension of a better highway system into the Black River valley where Lawrenceville and Valcourt are situated, has resulted in recent years in a distinct cut in what was never very large revenues. The result is the order permitting abandonment of what is left of the OMR on April 30th, 1965.

Thus, the remains of yet another Canadian short line will disappear from the railway map for good. It is true that the 1.4-mile spur from Eastray into Eastman will remain, but that is a relic of the Waterloo & Magog, rather than of the Orford Mountain Railway.



Number Three and its crew took time off near Bolton, Que., about year 1909, to be preserved photographically.

Locomotives

In its independent era, the Orford Mountain Railway possessed six locomotives, two of them purchased from the South Eastern Railway, two from its successor, the Montreal & Atlantic Railway, and two from the Canadian Pacific Railway:

4-4-0 1879 Kingston 13x18" 45"

- (1) 1 Ex SER #21 in 1891. Scrapped about 1900.
 (1) 2 " 20 " " " "

Originally 3'6" gauge engines built for the Lake Champlain & Saint Lawrence Junction Railway. Standard-gauged in 1881, becoming SER #21 and #20.

4-4-0 1880 Rhode Island 16x24" 63"

- (2) 2 Ser.888 Ex M&A #18, in 1901. Scrapped March 1909.

4-4-0 Rhode Island 14x24" 57"

- (2) 1 Ex M&A #2 about 1900. Scrapped 1910.

4-4-0 1878 Baldwin 17x24" 62"

- 3 Ser.4714 Ex CP #20 in 1906. Scrapped March 1910.

This locomotive, a sister of the "Countess of Dufferin", was built for contractor Joseph Whitehead, and was his #5, "Empress of India". It was sold to CPR in 1882, this engine becoming CP #147. It worked on ballast trains in the west, and on lines in southern BC in the Nineties, then was transferred to Montreal and used in suburban service. It was loaned to the Orford Mountain in 1906, and sold to it officially in July 1909.

4-4-0 1882 Kingston 17x24" 62"

(3) 2 Ex CP #45 in May 1909. Sold July 1910 to Baie-des-Ha!-Ha! Ry.
as their #2.

In the Canadian Pacific period, after 1910, 4-6-0s of a number of designs were used, the duties later falling on "E" class 4-6-0s, and D-4-gs. In the later years of steam when the line extended only to Valcourt, a D-10 was the usual assignment on the way freight.

Sources of information: 1- White, James. Altitudes in the Dominion of Canada, Ottawa, King's Printer, 1901. Also: Poor's Manual and the Official Guide, various editions; Railway Statistics, published annually by the Federal Government; Warrington and Nicholls, "A History of Chemistry in Canada".



Métro Montréal

According to a progress report given by Mr. Lucien L'Allier, Chairman and General Manager of the Montreal Transportation Commission to the Montreal City Council at the beginning of April, tunnelling on Montreal's Metro has passed the 75% mark. Mr. L'Allier's report indicated that contractors have completed the digging of more than 64000 feet of tunnel, the total initial length of which will be 85,182 feet.

Line No.1, under Western, Burnside, Ontario, and Demontigny Streets is 92% complete (as far as digging the tunnel is concerned). Excavation on Line No.2, under Berri and Vitre Streets is 84% finished, while tunnelling on the stretch under the St. Lawrence River to St.Helen's Island, Expo 67, and Longueuil is 28% complete.

Mr. L'Allier also announced that Canadian Vickers had completed the framing of five 3-car units (10 motor cars and 5 trailers) besides the prototype motor car now being equipped. It is expected that delivery of rolling stock for testing will commence about September 1st.

The M. T. C. informs us that the Car Inspection and Servicing Shop and the Track Shop constructed by the Commission at Youville are virtually completed. A start will be made shortly on the first section of the General Repair Shop. Track laying in the Shop Yards is practically complete, and tracks are now being installed in the tunnel of Line No.2.

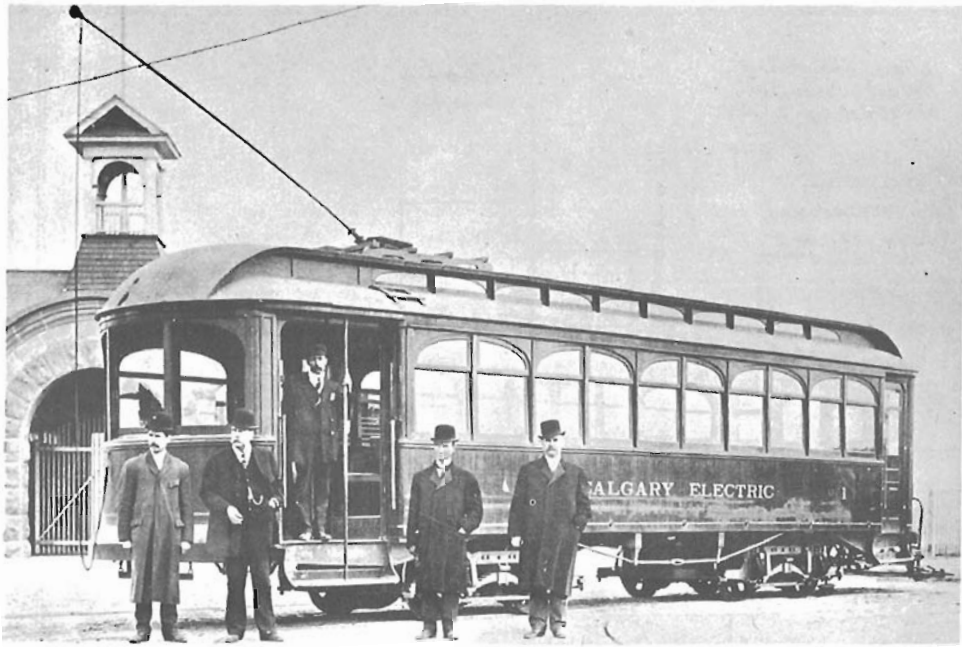

1912 Father put on his shirt with the tall stiff collar, Mother wore her high button shoes, Junior his Buster Brown suit, Sister her fresh white pinafore; their outing was a brand-new venture no one dared hope would become the "Greatest Outdoor Show on Earth" . . . and their means of travel to the First Calgary Stampede was public transit: the number 1 car of the original Calgary Municipal Railway (shown above at the old Stampede Gate).



-- J. Meikle.

CALGARY MUNICIPAL RAILWAY.

Operations on what was at first called the Calgary Electric Railway commenced on July 5, 1909. Two cars were used in the first operation on the "little belt" on Eighth Avenue between 2nd Street East and 1st St. West, on 1st Street West between 8th and 17th Avenues, on 17th Avenue between 1st Street West and 2nd St. East and on 2nd Street East between 17th Avenue and 8th Avenue.

Mr. Thomas Macauley was the first Superintendent and remained in the post until after World War I. He was succeeded by Mr. R.A. Brown, and Mr. Charles Comba was Superintendent during and after the 1939-1945 war.

The expansion of Calgary's street car system was very rapid in the years before 1914. In fact, 79 cars and six trailers had been purchased by the time hostilities broke out. The routes were designated by various shaped and colored signs, illuminated by colored bulbs

at night, on the front and sides of the roofs of the cars, as well as roller destination signs. About 1935, this system was supplanted by a system of perforated numbers, often referred to as "Jack-o-lanterns".

The early routes, which were changed from time to time over the years, were as follows:

Red	West Calgary - Burns Ave. with connection to the Grand Trunk stub line and the regular service to Bowness Park.
White	Elbow Park-East Calgary.
Blue	Southwest belt (inner & outer) 2nd St. E., 8th Ave., 1st St. W., 12th Ave. W., 14th St. W., 17th Ave.
Blue & Yellow	South Calgary loop line.

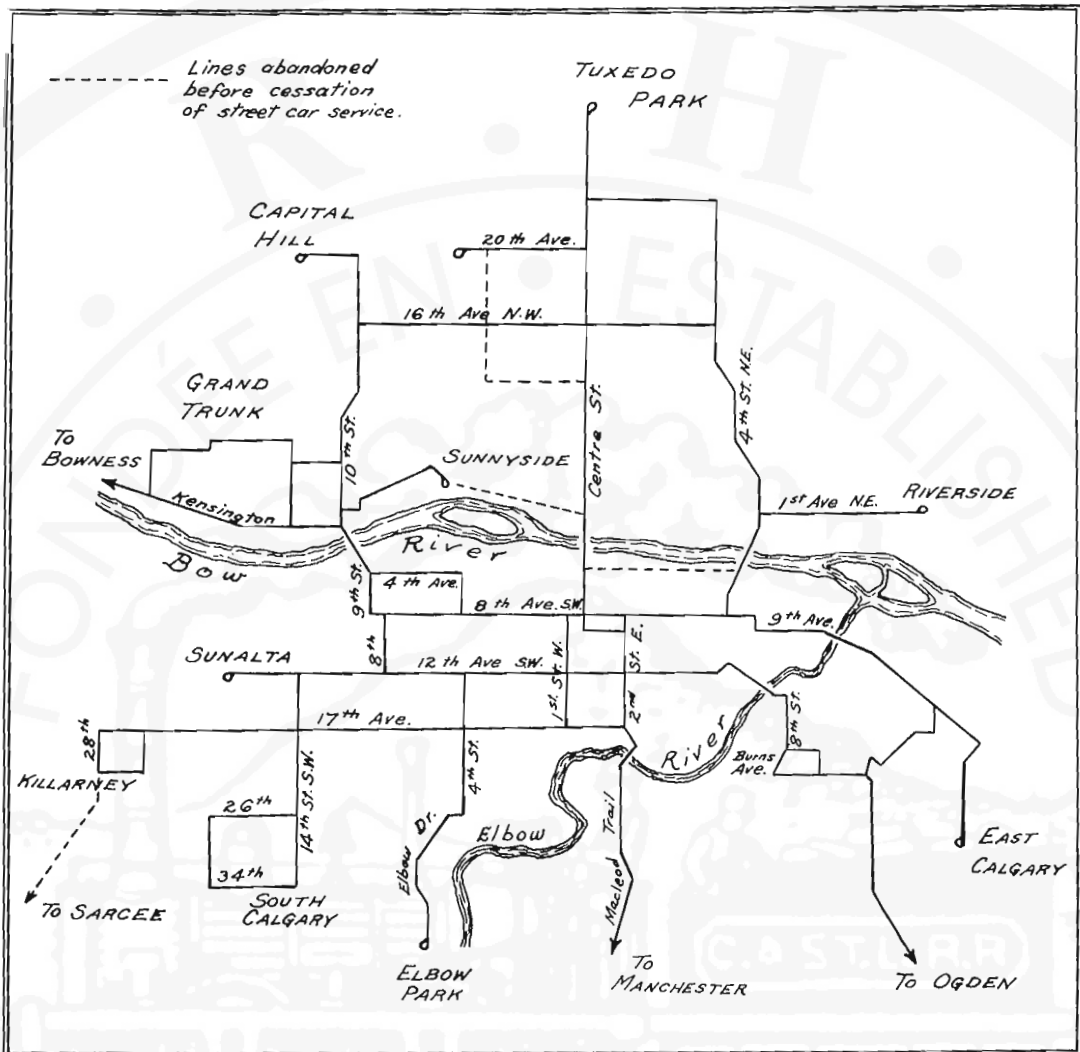

- Red & White North belt (inner & outer) 16th Ave., NW & NE, 4th St. E., 8th Ave., 4th St. W., 4th Ave., 10th St.W. with connection to Capital Hill stub line.
- Diamond (Blue & White) 1st St.W. & 8th Ave., to 18th St. W. & 12th Ave. (Sunalta)
- Star (Green & White) Tuxedo Park- Manchester.
- Red & Blue Sunnyside loop line.
- Oval (Red & White) Ogden - regular service.
- Yellow Arrow Killarney loop line.
- Sarcee Special service to Sarcee military camp during World War 1 and for a short time afterward. This line was built as an extension from the Killarney Line.
- Red Cross General Hospital (Riverside loop line) with stopover transfer privileges at the Public Market on 4th Ave. E.



In addition to the foregoing routes, the system operated cars in the morning and afternoon to the Ogden CPR Repair shops, picking up the employees at various points on the regular routes and transporting them to the shops, reversing the process in the late afternoon. On weekends and holidays in the summer special service was provided to Bowness Park, an amusement park operated by the Street Railway and located about nine miles west of the city. The six trailers were used exclusively in these two services, except during World War 1, when they were also used in the Sarcee service.

All the cars purchased new in the early days were single-end, short front vestibule, long rear vestibule types and were designed for two-man operation. Nos. 19-36 were single-truck cars without air brakes and were referred to by Calgarians as "dinkies". These cars, with their rather long rigid wheel-bases, had a propensity to derail on turnouts, particularly during the spring breakup when the roadbed was soft. Six of these cars were traded to Saskatoon in 1919 for six double-truck cars. Eight of the remaining cars were spliced in the system shops to make up four full length double truck cars with long front and rear vestibules. No. 22

was converted to a double-ender and provided service for a time after 1918 to bring returned soldiers from Sarcee into the city to attend a vocational school and return them at the school closing hour. Later it was used in emergencies only. No. 26, shorn of its rear vestibule and painted bright red, was used for many years as the Auxiliary or repair car, until supplanted by No. 80.

A freight operation was carried on in the period 1914-18 as a means of transporting supplies to Sarcee Camp. A number of 4-wheel box cars was constructed (numbered in the 100 series) and a freight motor with a cab on each end of a flat frame was built. After the war, the thrifty system officials converted the bodies of these box cars to shelters for passengers waiting at car stops in outlying parts of the city. One car, originally No. 8 was rebuilt as a combination passenger-baggage unit and operated to Bowness and Ogden every morning for years, mainly to pick up milk cans. It was numbered 300, and rebuilt in 1932 or 1933 as a passenger car, after which it carried the number 36.

When the shortage of manpower dictated conversion to one-man operation, Mr. Macauley's ingenuity came into play. In order to provide

both entrance and exit doors at the front (short-vestibuled) end of the cars, he removed the right front windows and the dashes below them and replaced them with "kitty-cornered" doors. The mechanism for opening and closing these doors was constructed out of used $\frac{1}{2}$ inch pipe. The only other system in Canada using this idea was Regina's. In the



case of the six dinkies later sold to Saskatoon on which this conversion was performed, the "Armstrong" brake lever was in the way of the new door, so Macauley had a wheel type brake rigging installed instead. A feature of the one-man cars was switch bars which hung in holes bored through the vestibule floor, so that the motorman could operate the track switches without getting out of the car. The bell cords used by the conductors under the two-man operation, were connected to the brake valves so that a passenger could stop the car by pulling the cord in an emergency. The motormen soon had knots tied in these just inside the vestibules.

Cars which normally operated on outlying routes were equipped with large locomotive type auxiliary headlights and scrapers for operation in snow. All cars except the dinkies were equipped with air whistles. Some of these were home-made and produced very piercing, unmelodious sounds. The Ogden and Bowness routes suffered from low voltage on the overhead, especially when the traffic was heavy. This

was later remedied by the construction of two portable sub-stations mounted on wheels, which were towed out to spurs at points near the outlying ends of the lines and connected up.

Because Calgary is quite hilly, many difficulties were encountered during winter operation. On two occasions, serious accidents occurred when cars came down the 14th Street West hill on the South Calgary line out of control. The first one occurred during World War I when No. 68 derailed and plunged into the basement of a drug store at 17th Ave. and 14th St. SW killing a passenger waiting for a car. During World War II, No. 67 collided with No. 91 at the same intersection badly damaging both cars. No fatalities were involved in this accident. Very rarely however, was the Calgary Street Railway entirely tied up. Other difficulties were flooded subways during heavy rainstorms. When these conditions prevailed, some sort of service was maintained even if some of the cars had to be operated in reverse for long distances.



Work equipment consisted of sweepers, track sprinklers, flat work motors (which were equipped with snow plows in winter) and a repair car for rerailling derailed cars and towing disabled cars. The system never had a tower car. At first a tower wagon was used, later succeeded by a series of tower trucks.



Calgary's pride and joy with Motorman Huss and Conductor-Announcer Bishop. Photo from J.Meikle and C. T. S.

The Calgary Municipal's pride and joy was its sightseeing car. This was similar to those operated in Montreal, Edmonton and Vancouver but was a particularly ornate one. The management, in fact, was very careful about who operated this car and nobody on the spare board was likely to get a chance at it.

In addition to the "Saskatoon Swap" the Calgary system bought six cars during the immediate post-war era from Springfield, Massachusetts. These cars had short vestibules at both ends, and were never converted to the two door front set-up. They were used mainly in the Ogden shop shuttle service. Having originally been built as double-enders, they were for a short time during the "hungry thirties" reconverted to double-end operation on an experimental stub type operation, but this was soon abandoned.

In the late twenties, a program of installing rear treadle

Page 77 - Photo of No.1, courtesy of Calgary Transit System.

Page 79 - An early shot at the car-barn. Note sprinkler behind No.18; cars in next 2 stalls believed to be 16 & 17. Note original tower wagon. From J.Meikle.

Page 80 - Interior of a "Prairie" type car with "Kitty-cornered" entrance doors. One of the portable substations. Believed taken on Burns Avenue.

Page 82 - Eighth Avenue, looking west from the Post Office, showing No. 7 in two-man car days. From J.Meikle. After the Farewell Run, no.14 took last place in a scrap-line after completing the final run on December 29th, 1950. A.Clegg.



exits was commenced by the maintenance shops. Eventually, eleven of the cars were so equipped. Since all the Calgary cars, when converted to one-man operation, boasted of "smokers" in the rear vestibules, the installation of the treadle exits involved cutting down on the size of the smokers to the extent of the partitions around the treadle exits. In 1928, the system purchased three double-truck safety cars from Canadian Car Co. Montreal, followed by six more the following

year. These cars had air-operated front doors, treadle rear exits and 26" wheels, and were the last street cars to be acquired. The first busses went into service within a few years, and the complete conversion to trolley coaches and busses took place in the years immediately following World War II. The last street car run took place on December 29, 1950, performed by Car No. 14, operated by Bob Thompson who was number one on the seniority roster of motormen.

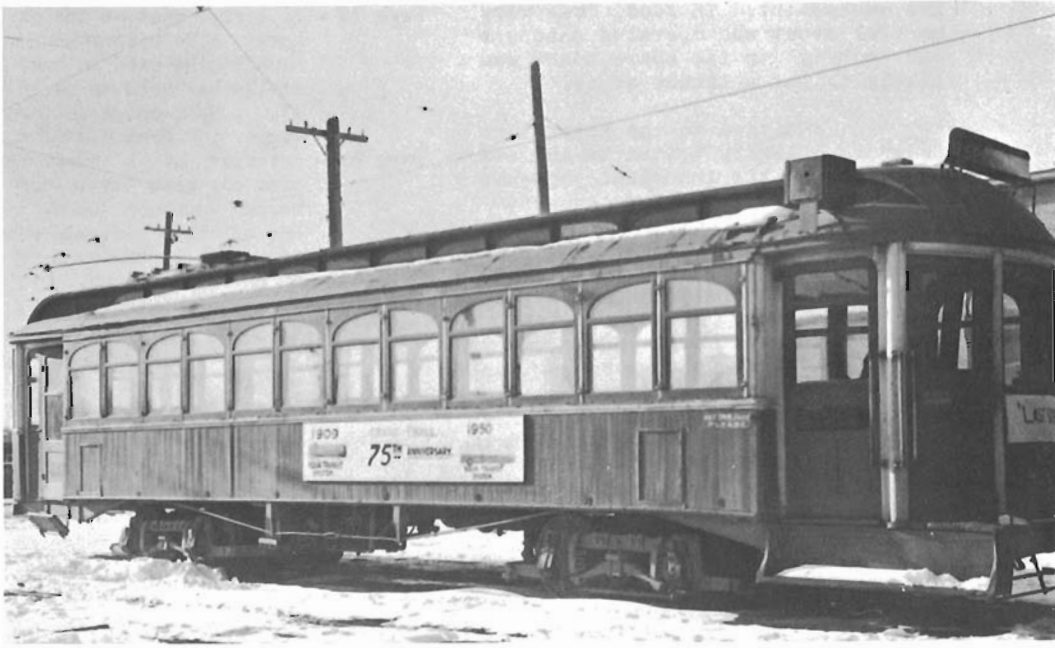

Additional notes on the CALGARY ELECTRIC RAILWAY
 CALGARY MUNICIPAL RAILWAY
 CALGARY TRANSIT SYSTEM
 provided by Mr.J.K.Gush, Assistant to Mr.R.H.Wray,
 Manager, Calgary Transit System.

The inaugural run of the Calgary Electric Railway on July 5, 1909, was attended by Mayor Jamieson of Calgary, along with the Aldermen, Commissioner Graves, and C.E.Ry. Superintendent Macauley. As the first car passed down Eighth Avenue, it was cheered by citizens of the growing community and by the local businessmen. It was reported that the Indians in the area were at first frightened by the new electric machines and hid behind the buildings. Once the initial shock was over, however, and they became accustomed to the new means of transit, they "took to" the trams and spent much of their spare money joy-riding on the cars.

The initial expansion of Calgary's street car system was very rapid. By the end of 1909, the System comprised of thirteen miles of line, and by 1912 service was provided to Crescent Heights, the Ogden CPR Shops and Bowness Park.

In 1913, an electric sightseeing car was purchased by the C.M.R. This observation car had a canvas canopy top and large plate glass mirrors on the sides. Fare for a two-hour sightseeing trip was 25¢.

One-man car operation was introduced in 1917, due to labour shortages during the 1914-1918 war. Bus operation by the C.M.R. commenced in 1932 using two Leyland buses on the Mount Royal route: in 1944, five Ford gas buses were added to the fleet. The first trolleycoach route was inaugurated in June, 1947, on the Crescent Heights line, while the conversion of the system to rubber-tired vehicles was completed on December 29, 1950, the last electric cars being operated on the Ogden route on that date.

The name of the organization, operated by the City of Calgary, was changed to Calgary Transit System, and now operates a fleet of 105 trolleycoaches and 88 motor buses serving an area of 155 square miles with a population of approximately 300,000.

In 1909, passengers carried by the original electric cars totalled 1,924,928, while in recent years the Transit System has carried in the vicinity of 25 million riders per annum.

A roster of equipment operated by the
 Calgary Electric Railway -
 Calgary Municipal Railway
 will be included in next month's issue
 of Canadian Rail.

Canadian Pacific

MOTIVE POWER

Changes in ownership of motive power by the Canadian Pacific Railway during the year 1964 were as follows:

Locomotive Disposals (Scrapped unless underlined)

4-6-0	D-10:	842, <u>894</u> , 988, <u>1088</u>
4-6-2	G- 5:	1200, <u>1202</u> , 1210, <u>1211</u> , 1212, 1214, 1227, 1234, <u>1238</u> , 1243, <u>1246</u> , 1248, 1270, <u>1286</u> , 1287, 1290, <u>1293</u> , 1298.
	G- 3:	<u>2343</u> , 2367, 2392, 2409, 2429, 2433, 2446, 2449, 2451.
4-6-4	H- 1:	<u>2816</u> , <u>2860</u> .
2-8-0	N- 2:	<u>3651</u> , <u>3659</u> .
2-8-2	P- 1:	<u>5131</u> , 5134, 5221, 5244.
	P- 2:	5392, <u>5433</u> , 5434, 5457, 5469, 5471.
0-8-0	V- 4:	6921, <u>6937</u> , 6949.

The above numbers shown underlined have been preserved:

1238	-	sold to Mr. George Hart, Pennsylvania, U.S.A.	
1286	-	" " " " " "	
1246	-	sold to Steamtown, North Walpole, N.H. U.S.A.	
1293	-	" " " " " "	(#)
2816	-	" " " " " "	
894	-	City of Kitchener, Ontario.	
1088	-	City of Fort William, Ontario.	
2860	-	City of Vancouver, British Columbia.	
3651	-	City of Lethbridge, Alberta.	(#)
5433	-	City of Chapleau, Ontario.	

(#)-See page 70 - this issue)

Diesel-electric units rebuilt and renumbered.

As at mid-April, 1965, six Canadian Pacific diesel-electric units had been rebuilt into 2400 h.p. Road switchers by M.L.W. as follows:

4098	now	4201	MLW serial number	84839
8469		4202		84840
4001		4203		84841
4026		4204		84842
4045		4205		84843
4048		4206		84844

In addition, units 4419 and 4027 were undergoing rebuilding and will emerge as 4207 and 4208, but not necessarily in that order. The new #4200 is already occupied by former #8300, built in 1963.

No rebuilt GMDL units had emerged as new 2500 h.p. Road switchers at publication time, but former "GP" series 8200 to 8213, built in 1963 and 1964, are currently being renumbered 5000 to 5013, and the rebuilt units will carry on from 5014 upward.

ROLLING STOCK

Canadian Pacific is currently taking delivery of record quantities of new freight rolling stock. The situation in mid-April was as follows:

Piggyback flatcars: order placed with International Equipment Company for 125 - 54'4" flats now almost completed.
Covered Hoppers: about half an order for 500 - 100 ton steel

(Continued on Page 89)

WHEEL SLIP

AND SLIP DETECTION ON DIESEL ELECTRIC LOCOMOTIVES.

--B.A. Biglow.

In the days of the steam locomotive, wheel slip was a spectacular affair. The slipping of the mighty iron horse was accompanied by visible and audible indications, well known to all but the youngest of railway employees and "railfans". Wheel slip on a modern diesel-electric locomotive, however, gives no such readily-apparent indications --- not even to a skilful operator in the control cab. This unobserved slipping, if uncorrected, can be the cause of a good deal of serious trouble, and has led to the use of wheel slip detectors.

The oldest wheel slip detectors utilized the electrical characteristics of the motors

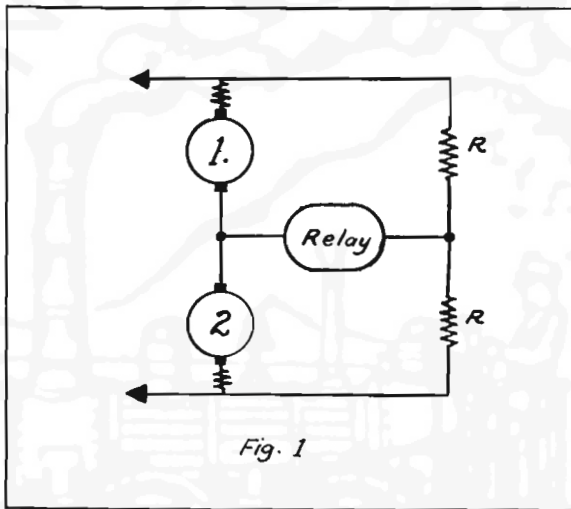

Fig. 1

to predict axle speeds and hence give an indication of a slipping axle. If the motors were connected in series, a bridge circuit, similar to Figure 1, detects axle slipping. If the speed of motor #1 is significantly different from that of motor #2, a voltage differential exists, causing the relay to operate. This circuit historically has been quite satisfactory for slips at low speeds. The sensitivity is reduced, however, when field shunting is applied to the motor fields as a transition step.

G. M. locomotives compare currents in a magnetic circuit. (See Figure 2). If i_1 differs enough from i_2 , the net magnetic force closes the relay contacts. This detector works for parallel or series connections of motors. A more sensitive relay is sometimes fitted to detect wheel creep.

For parallel connection of motors, the circuit shown in Fig. 3 is usually used. If i_1 differs sufficiently from i_2 , the voltage difference across the fields operates the relay. The sensitivity of this circuit is normally barely adequate, especially if the motor fields have been shunted. Thus wheel slip detection at high speeds is generally poor.

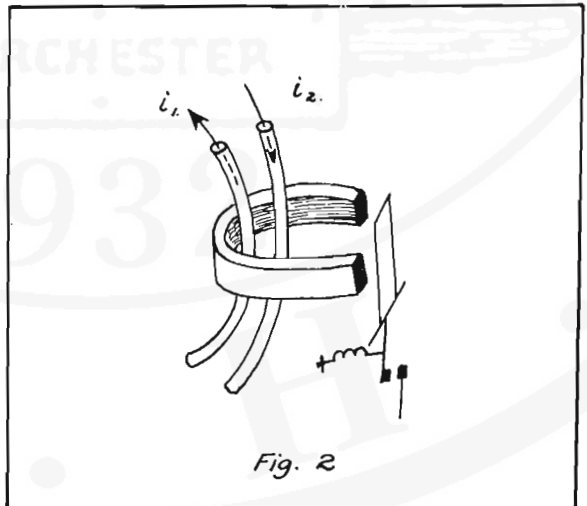

Fig. 2

A traction motor is designed to withstand centrifugal forces only up to a given speed. Operation above this speed will cause commutator deformation and eventual motor destruction. Motor failures from over speed - at first somewhat a mystery - eventually led to the discovery of high speed wheel slipping. Slipping at high speeds was previously thought to be rare, due to the locomotive's low tractive effort at these high speeds.

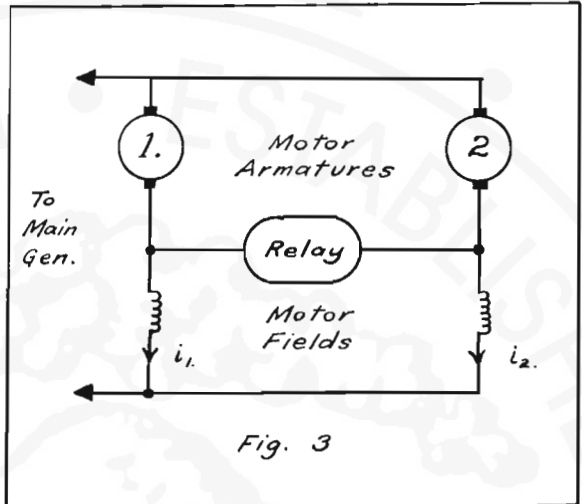

Fig. 3

Detectors, which measure each axle speed independently were developed to detect these high-speed wheel slips accurately. A comparison circuit compares each axle speed against the others. If the difference is excessive, a wheel slip correction circuit is operated. These detectors must have decreasing sensitivity with increase in speed in order to allow for slight differences in wheel diameters. See Figure 4.

Trial installations of this type of detector, as developed by the General Electric Company are fitted on C.N.R. units 3660 to 3664 and 3880 to 3884. A comparable detector, developed by the C.N.'s Technical Research Branch, and operating along similar lines, has been fitted to C.N.R. unit 3117. Both designs are presently being tested by the railway under actual operating conditions.

The factors leading to wheel slip, and the methods of correction, have not been discussed in this summary, but may form the basis for a future article on this subject.

A DATE TO REMEMBER

May 29-30.

CRHA Special train, Montreal to Drummondville and return
 Leaves Central Station 10:00 am Standard time
 CRHA Special train, Montreal to Ottawa and return
 Leaves Central Station 8:35 am Standard time

Fares - \$8.50 per day - both days \$16.00
 Children - Half fare; under 5 - Free.

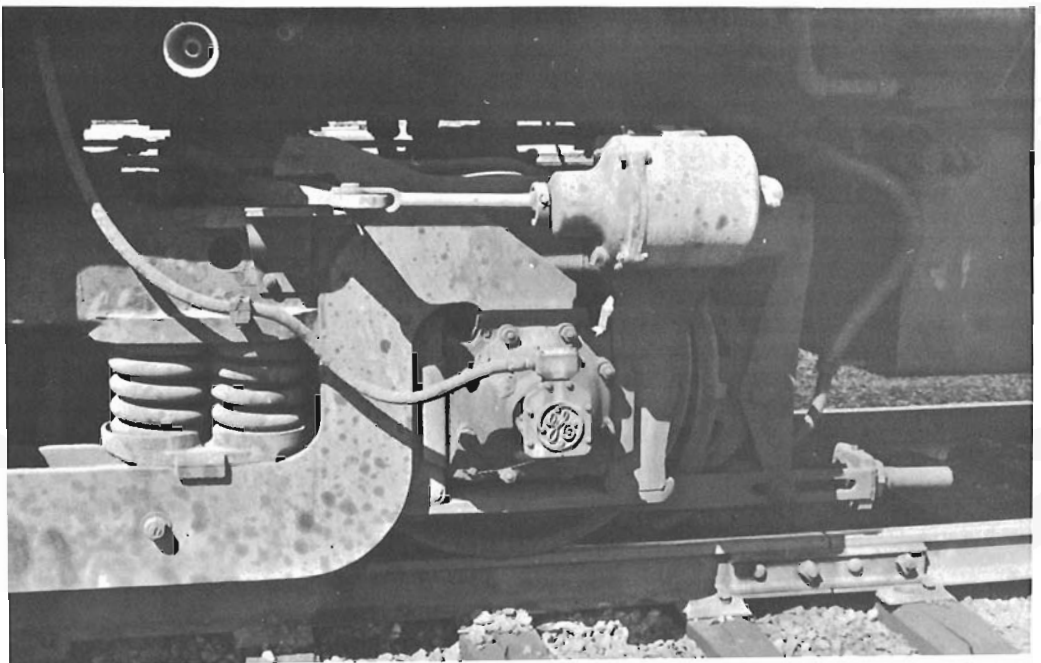
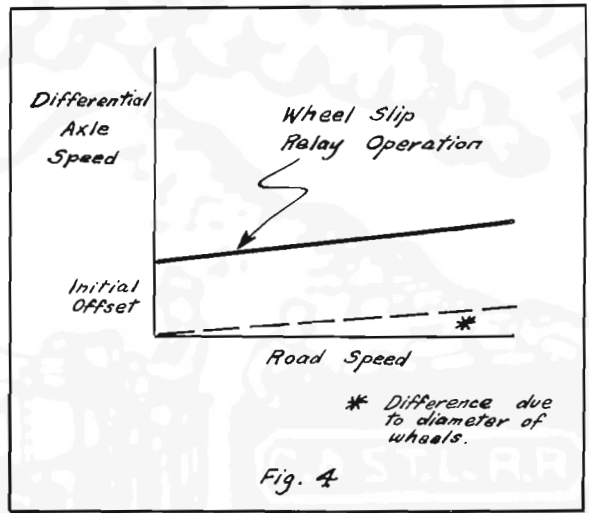



PASSENGER EQUIPMENT CHANGES

Additional details concerning the 34 sleeping cars recently purchased by CN and the 10 cars leased by the National System are now available.

Leased: The six N&W (Wabash) sleepers will be used Montreal to Toronto between mid-June and mid-September. Names of the cars, built by ACF in 1950 are: Blue Boy, Blue Cloud, Blue Gazelle, Blue Horizon, Blue Knight, and Blue Sky.

During the same period, the following cars will be operated Toronto-Chicago: Erie Lackawanna cars "Pride of Youngstown" and "Spirit of Youngstown", built by Pullman Standard in 1953; Louisville & Nashville RR or C. & E.I. RR cars of the "Pine" series, built by Pullman Standard in 1954. These cars will be assigned to Pullman operations to replace four CN "Green" series sleepers which will be operated Toronto-Timmins-Noranda.

Purchased: Two BAR sleepers (6 sec. 6 roomettes, 4 double bedrooms) "North Twin Lake" No.80 and "South Twin Lake" No.81. They will be renamed "Green Gables" CN 1190 and "Greenoch" CN 1191. They will be used Montreal-New York. They were built by Pullman Standard in 1954, are stainless steel and have been renovated at Port Huron Shops.

The twenty ex-NYC sleepers (10 roomettes, 6 d.b.r. - Pullman Standard, 1950) are to be refurbished during the summer at the various car shops across the System. The Frisco cars (14 roomettes, 4 d.b.r.) were built by Pullman Standard in 1948. They are to be rebuilt at Pointe St. Charles Shops later in the year. According to present plans, their stainless steel sheathing will be removed during the renovation.

Following is a list showing the former NYC or Frisco number and name, together with the name and number assigned by the Canadian National:

NYC 10141	Powder River	CN Exploits River	CN 2075
10144	Penobscot River	Margaree River	2076
10152	Miami River	Mabou River	2077
10157	Winding River	Sable River	2078
10161	Agawan River	Restigouche River	2079
10162	Deer River	Petitcodiac River	2080
10165	East River	Riviere du Loup	2081
10167	Manistee River	Riviere au Renard	2082
10174	St.Regis River	Riviere Rouge	2083
10188	St.Francis River	Riviere Raquette	2084
10197	Licking River	Nipigon River	2085
10199	Chicopee River	Pembina River	2086
10213	Hocking River	Saskatchewan River	2087
10215	Huron River	Prairie River	2088
10216	Housatonic River	Peace River	2089
10218	Niagara River	Smoky River	2090
10222	Saugus River	Skeena River	2091
10223	Scioto River	Hay River	2092
10230	Oswegatchie River	Yukon River	2093
10233	Kanakee River	Rideau River	2094
Frisco 1450	Pierre Laclède	Churchill Falls	2095
1451	Thomas Hart Benton	Topsail Falls	2096
1454	Auguste Chouteau	Sisiboo Falls	2097
1457	Meramac River	Reversing Falls	2098
1458	Osage River	Pine Falls	2099
1459	Gasconade River	Horseshoe Falls	2100
1460	Nangua River	Kakabeka Falls	2101
1461	James River	Pyramid Falls	2102
1462	Grand River	Teckawa Falls	2103
1465	Spring River	Ocean Falls	2104
1466	Cimarron River	Rainbow Falls	2105
1464	Neosho River	Alexandra Falls	2106

Conversions: In addition, the CNR will convert twenty coaches to Coach-Lounges. The 44 coach-seat, 24 lounge-seat units will be numbered 3020 to 3039, and are to be converted from E-M coaches 5451, 5546, 5550, 5555, 5556, 5561, 5563, 5565, 5566, 5567, 5568, 5572, 5577, 5600, 5604, 5606, 5607, 5609, 5613, & 5614. These will bring the CN's inventory of Coach-Lounge cars to forty units.

Other conversions scheduled for the current year:

- 19 forty-eight seat diners
 #1360 - 1368 converted from Parlor Grill #900-908.
 #1369 - 1378 from Coaches 5384, 5385,
 5387, 5391, 5392,
 5397, 5398, 5401,
 5408, 5410.
- 9 Diner-Lounges (32 dining seats - 12 lounge seats)
 #1351 - 1359 converted from 48 seat diners
 #1351 - 1359.
- 10 Club-Lounges (18 in refreshment section - 17 to 21 in lounge)
 #2316 - 2325 converted from Buffet Parlors
 #875 St.Charles
 876 St.Francis
 877 St.Louis
 878 St.Peter
 879 Amethyst
 880 Alleyne
 884 Manitoba
 and from B.B.L.cars,
 #1062 Fort Garry
 1063 Fort Lawrence
 1071 Fort Augustus

Canadian Pacific

(Continued from Page 84)

covered hoppers had been completed by National Steel Car Co. These cars are numbered from 386000 upward.
 Box cars: About 200 of an order for 500 70 ton box cars delivered by Hawker Siddeley (Canada) Ltd. These cars commence at No.80500 and follow immediately upon order for 500 similar cars built by H.S.Ltd between December and March, numbered 80000 to 80499.

The following equipment has been ordered but is not yet in production:

- 150 mechanical refrigerators - Hawker Siddeley.
 400 steel covered hopper cars - National Steel Car
 150 piggyback flat cars - Int'l.Equipment Co.
 25 bi-level flat cars - National Steel Car.
 25 tri-level flat cars " " "

It is rumoured that the company has under consideration further orders for bi-level and tri-level cars to meet a current shortage, and also that a further sixteen diesel locomotives will be dealt with in the rebuilding and updating programme.

Notes and News

by Ferro



- ★ A new name in sleeping accomodation bargains will be introduced by CN to its travelling customers on its "name" trains this summer. The new name is "Dormette". It is applied to a series of open section space sleeping cars that will operate on the Super Continental, Panorama, Ocean Limited, and Scotian. "Dormettes" will be marshalled directly at the head-end of the trains, ahead of the coaches. For "Dormette" sleeping accomodation, passengers will pay less than standard upper, lower and section prices. Complimentary meals will be served in Dinette or Cafeteria cars, and "Dormette" passengers also may enjoy the facilities of the coach lounge. "Dormettes" will be made available to the general public for individual travel, but are ideal for group travel such as student and club tours -- truly a tourist bargain.

- ★ No more aboard a CN train
 Will food and news agents be found.
 No more their tiresome harsh refrain
 Throughout the coach will sound.
 Each one of them has been removed
 CN declares they're obsolete.
 Perhaps coach atmosphere's improved
 But atmosphere's no good to eat!
 (anon.)

- ★ "Ah the woes of the public relations man," says the Kingston Whig-Standard in a news report. "Five important Canadian National Railways officials, including one of the company's PR men, were in Napanee last week to explain changes in service to the community. After a press conference which lasted over an hour, the changes were all explained and the PR man heaved a sigh of relief and leaned back in his chair to enjoy a cup of coffee. One of the reporters present, taking advantage of the relaxed atmosphere, decided to pay a compliment to the men present. 'You know, one train you fellows really do a good job on is the Canadian running out west,' he commented with a smile. The PR man groaned. 'There's our press conference all shot to hell. Our train is called the Super Continental. The other is Brand X.' "

- ★ A new method of burning pulverized coal in a diesel engine might recapture the one-million-ton coal market lost when Canadian railways started burning oil. Mr. John H. Delaney, United Mine Workers district 26 international board member recently described an experiment conducted in the U.S. in October, 1964, using pulverized low ash bituminous coal as a substitute for 100 percent, number two diesel fuel oil in a conventional one cylinder, four stroke engine. Mr. Delaney said the demonstration appeared successful enough to warrant further study and another test is planned.

- ★ CN is discontinuing four express freight trains that operate between Toronto and London, Ontario, in favour of a trucking service. Most of the new truck service will be let out on contract.

- ★ Thomas Fuller Construction Co. Ltd. of Ottawa has been advised that it is low bidder on a contract from the National Capital Commission for construction of that city's new Union Station. The new station is to be built some miles from the present downtown site in an effort to beautify Ottawa by removal of its downtown railway tracks. It is to be greatly hoped that nobody gets the idea of beautifying the whole of Canada in the same manner!
- ★ CN has been authorized by the Board of Transport Commissioners to abandon two rail lines in southwestern Ontario. The railway was given authority to close at any time after June 30, its 10½-mile line between Glencoe and Alvinston, midway between London and Chatham, and a 6.85-mile line between Woodstock and Hickson. There were no regular passenger or freight services on either line but car-load freight pickup and delivery was available on a when required basis.
- ★ Expo 67, the 1967 Canadian world exhibition has received Federal government approval to purchase a system of secondary transportation from the Habegger Company of Thun, Switzerland. Habegger provided the minirail and tele-canopy for the 1964 Lausanne exhibition. The minirail is a small monorail system in which passengers sit in open air while travelling through the pavilion areas. The tele-canopy is a system which runs on two rails in normal railroad fashion but with the passengers facing one side. They mount and dismount the cars from a huge disk which revolves at the same speed as the passing trains. These novelties will supplement the mainstay of the Expo transportation system, that being an orthodox standard gauge electric railway system.
- ★ The British, as an experiment, have placed a U.S.-style "bunny" on the evening train from Manchester to Alderley Edge, to "brighten up travel". The hostess passes out chocolates and asks passengers if they are comfortable. (What corrective action is taken in the event of a negative reply is not indicated -- Ed.)

Red to Pink

Red White and Blue fares on many C N R runs were adjusted on May 1st last. In most cases the low Red fares were augmented, while the more expensive Blue fares were slightly reduced. This does not apply in all cases, however. On the Halifax-Montreal run, Red fares are up by \$1.00 while Blue fares are reduced by a like amount. Montreal-Ottawa Red is up 20¢, while the Blue is down 20¢. Toronto-Vancouver passengers will pay an extra 50¢, no matter which day they travel, as will Winnipeg-Prince Albert patrons. No change is recorded in Montreal-Edmundston Red rates, but Blue fares, between these points, have been reduced by \$1.80. (There is no service between these points, however, except via mixed trains which lay over 17 hours at Monk, and make no connections at Joffre.) Montreal-Toronto Blue fares have been decreased by 70¢, but Red day travelers will pay an extra 60¢ for the journey.

We hope to have a complete report on the Summer Timetables of all Canadian railways in the next month's issue of 'Canadian Rail'.

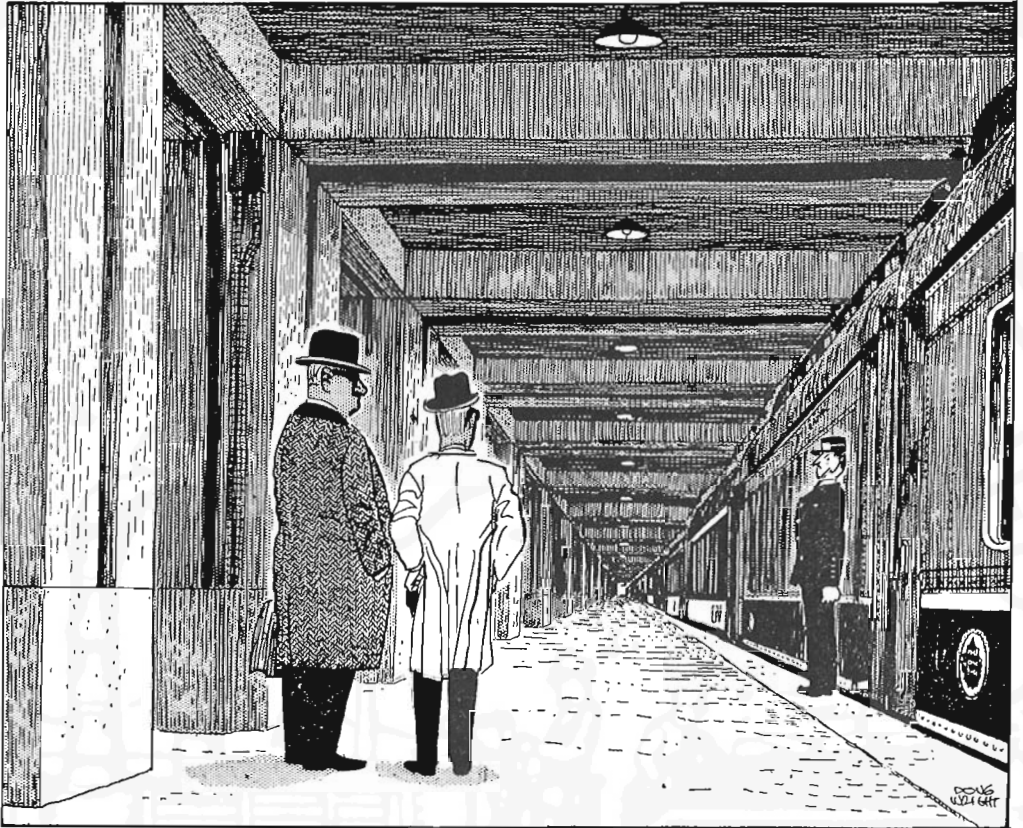

"If two suburbs can squabble 20 years over one underpass, as at Rockland, how long can seven suburbs fight over converting 17 miles of railroad to rapid transit?"

CANADIAN RAILROAD HISTORICAL ASSOCIATION

Established 1932 • Box 22 • Station B • Montreal 2 • Quebec • Incorporated 1941

CANADIAN RAIL: Published eleven times annually by the Publications Committee, Canadian Railroad Historical Association. Subscription included with Associate Membership: \$4.00 annually.

CHAIRMAN, PUBLICATIONS COMMITTEE: David R. Henderson

EDITOR, CANADIAN RAIL: Anthony Clegg
ASSISTANT EDITOR: William Pharoah
DISTRIBUTION: John W. Saunders
COMMITTEE: Frederick F. Angus
 Hyman Mandel
 Robert Halfyard
 Omer Lavallee
 William Fowle
ADVERTISING MANAGER: S.S. Worthen
MEMBERSHIP SECRETARY: Michael Leduc



**SUBSCRIBERS!
 BEFORE YOU MOVE—WRITE!**

At least 5 weeks before you move, send us a letter, a card, or a post-office change-of-address form telling us both your **OLD** and your **NEW** addresses.

ASSOCIATION REPRESENTATIVES:

OTTAWA VALLEY: Kenneth F. Chivers, Apartment 3, 67 Somerset Street West, Ottawa, Ont.
PACIFIC COAST: Peter Cox, 2936 West 28th Avenue, Vancouver 8, B.C.
ALGOMA: William F. Cooksley, 594 McDonald Avenue, Sault Ste. Marie, Ont.
SASKATCHEWAN: J.S. Nicolson, 2306 Arnold Street, Saskatoon, Saskatchewan
ROCKY MOUNTAIN: V.H. Coley, 11243-72 Ave., Edmonton, Alberta
FAR EAST: William D. McKeown, 900 Oaza Senriyama, Suita City, Osaka, Japan
BRITISH ISLES: John H. Sanders, 10 Church St., Ampthill, Bedford, England