

Canadian Rail

THE MAGAZINE OF CANADA'S RAILWAY HISTORY

No. 458



MAY - JUNE 1997



PUBLISHED BI-MONTHLY BY THE CANADIAN RAILROAD HISTORICAL ASSOCIATION
PUBLIE TOUS LES DEUX MOIS PAR L'ASSOCIATION CANADIENNE D'HISTOIRE FERROVIAIRE



CANADIAN RAIL

ISSN 0008-4875



PUBLISHED BI-MONTHLY BY THE CANADIAN RAILROAD HISTORICAL ASSOCIATION

TABLE OF CONTENTS

THE POSTER EXPRESS....LA PUB ENTRE EN GARE.....	GUY PEPIN.....	59
THE FIRST CONSOLIDATION BUILT IN CANADA.....	FRED ANGUS.....	67
SIXTY YEARS OF CRHA PUBLICATIONS.....	FRED ANGUS.....	80
THE BUSINESS CAR.....		82

FRONT COVER: A CPR passenger train at Glacier British Columbia about 1890. Motive power is No. 401, the first Consolidation type locomotive built in Canada. These 2-8-0s were regularly used in the Selkirks at that time. National Archives of Canada, Photo No. PA-25053.

BELOW: An elaborate poster, printed in 1893, advertising the fact that the CPR operated three passenger trains daily (except Sunday) between Toronto and Chicago, the site of the World's Columbian Exposition of that year. Much was made of the fact that all the cars were vestibuled.

For your membership in the CRHA, which includes a subscription to Canadian Rail, write to:

CRHA, 120 Rue St-Pierre, St. Constant, Que. J5A 2G9

Membership Dues for 1997:

In Canada: \$35.00 (including GST)
United States: \$30.00 in U.S. funds.

Canadian Rail is continually in need of news, stories, historical data, photos, maps and other material. Please send all contributions to the editor: Fred F. Angus, 3021 Trafalgar Ave. Montreal, P.Q. H3Y 1H3. No payment can be made for contributions, but the contributor will be given credit for material submitted. Material will be returned to the contributor if requested. Remember "Knowledge is of little value unless it is shared with others".

EDITOR: Fred F. Angus

CO-EDITOR: Douglas N.W. Smith

ASSOCIATE EDITOR (Motive Power): Hugues W. Bonin

DISTRIBUTION: Gerard Frechette

LAYOUT: Fred F. Angus

PRINTING: Procel Printing

The Poster Express. A Century of Railway Posters

La Pub Entre en Gare... Un Siècle d'Affiches Ferroviaires d'Ici et d'Ailleurs

Guy Pépin, guest curator - conservateur invité

The history of the railway poster is intimately related to the history of the railway and its users. It is also the history of a very special form of advertisement which, thanks to the work of several artists, demonstrates the evolution in the use of pictures to promote among others, immigration, tourism or even the war effort.

This exhibition, realized by the Canadian Railway Museum at Delson/Saint-Constant with the participation of *La vie du Rail* and *Le Musée du chemin de fer français - Mulhouse (SNCF)*, travels across time and space, and look at six important phases of both the history of posters and of the railway. More than a simple stylistic or aesthetic thread, this approach reminds us how the railway was and still is an important moving force of social and economic activities for any country.

THE BEGINNINGS (1850-1880)

The first forms of railway posters were representative of the beginning of the railway in Canada. At that particular time, the railway companies were just in their infancy, looking for a clientele and for financial security. Since the very first day, the railway companies used the poster to promote and publicize their activities. These posters were quite simple, seldom more than typographic extravaganza, literally covered with all kinds of information on new lines, transportation facilities etc.

The use of typography in a graphic way was generalized. This technique, standard in the printing industry, was simple and did not need elaborate means. It was possible for railway companies to design, produce and spread their advertisement on their territory. Smaller formats were preferred because they were particularly well adapted for distribution on a large scale. They could be used on several sites, from station walls to telegraph poles and make-shift panels.

At that time, the railway industry and its advertisements were new, and as such were looking everywhere for a new direction for a vocation.

With the typography, of that period, page publishing and design were limited to a simple selection of fonts and ornamental borders. For that reason, some typographers were using colour in their composition so as to enhance the appearance, sometime to the detriment of legibility.

The railway poster as such, appeared in the 1890's in the wake of the evolution of passenger transportation. Nonetheless, always looking to improve their image and to acquire new clients, the railway companies rapidly employed a new form of advertisement, the illustrated poster, and a new technique, colour lithography. A development of the industrial revolution, this technique permitted the large scale reproduction of colour illustrations, executed with ink or a pen on a chalk stone chemically prepared for the occasion. The first colour poster was created by the Frenchman Jules Chéret in the 1880's. Hugo Alési, another French artist, was known as the "father of the railway poster". It was he who, in

L'histoire de l'affiche ferroviaire, c'est à la fois celle du chemin de fer et celle de ses usagers. C'est aussi l'histoire d'une forme publicitaire qui, par le travail de nombreux artisans, nous informe sur l'évolution des manières de faire et de faire voir par l'image, les orientations de cette industrie depuis ses débuts.

Cette exposition présentée par le Musée ferroviaire canadien de Delson/Saint-Constant, se veut un parcours dans le temps...un regard sur cinq moments forts de l'histoire de l'affiche publicitaire mise au service du chemin de fer canadien. Un volet supplémentaire traite des affiches produites pour les employés eux-mêmes.

Parallèlement à la présentation de cet itinéraire canadien, ce parcours intègre un volet étranger issu d'affiches ferroviaires françaises. Plus qu'un simple rapprochement stylistique, ce lien nous rappelle le rôle du chemin de fer en tant que moteur de la réalité sociale et économique d'un pays.

LES DÉBUTS (1850-1880)

Les premières formes d'affiches ferroviaires sont représentatives des débuts du chemin de fer au Canada. Une phase de développement où l'industrie du chemin de fer naissant est en quête de clientèles d'usagers et de sources de financement. Dès leurs débuts, les compagnies ferroviaires utilisent, pour promouvoir et rentabiliser l'établissement de leurs réseaux, des affiches publicitaires présentant une cascade d'informations sur l'inauguration de nouvelles lignes, les facilités de transport et des invitations de toutes sortes.

La plupart de ces affiches sont réalisées en typographie. Cette technique standard d'imprimerie qui nécessite peu de moyens, permet à ces compagnies de produire et de diffuser leurs affiches sur l'ensemble des territoires qu'elles desservent. Leurs petits formats facilitent aussi leurs diffusions à grandes échelles. Elles peuvent être placées à divers endroits comme sur les murs des gares, dans les villes et campagnes sur des poteaux et panneaux de fortunes.

La typographie, à cette époque, ne permet qu'une mise en page limitée par le simple choix de lettres et de bordures d'ornementation. Pour cette raison, certains typographes s'appliquent à créer des formats plus attrayants en intégrant la couleur à leurs compositions.

L'affiche ferroviaire illustrée apparaîtra tardivement à la fin du 19e siècle, avec l'évolution du transport de passagers. Cependant, pour attirer les regards sur leurs réalisations, les compagnies ferroviaires font produire dès leurs débuts, des affiches illustrées faisant appel à une nouvelle technique d'impression: la lithographie couleur. Développée industriellement, cette technique permet de reproduire sur papier à de multiples exemplaires, une illustration couleur exécutée à l'encre ou au crayon sur une plaque de pierre calcaire préparée chimiquement.

Intercolonial
RAILWAY
CANADA

NOW OPEN BETWEEN
QUEBEC, RESTIGOUCHE
MIRAMICHI, PICTOU,
ST. JOHN AND HALIFAX

 **THROUGH EXPRESS TRAINS**
Between **QUEBEC** and **HALIFAX** in **24 HOURS.**

STEEL RAILS AND IRON BRIDGES.

No Custom House Obstructions. Excellent Refreshment Rooms.

NO CHANGE OF CARS.

PULLMAN PALACE SLEEPING CARS
ON ALL EXPRESS TRAINS.

CLOSE CONNECTIONS made at Quebec with the GRAND TRUNK R'Y and Steamers between Montreal and Quebec.
THE SCENERY ALONG THE LINE IS THE FINEST ON THE CONTINENT. THE ENGINES AND CARS
ARE ALL NEW AND OF THE VERY BEST DESCRIPTION.

FARES CHEAPER AND TIME QUICKER THAN BY ANY OTHER LINE.

J. J. WALLACE, Gen'l Ticket Agent. R. LUTTRELL, Superintendent. O. J. BRYDOES, Gen'l Supt. Government Railways.

1890, produced the first railway poster with a "paysage" for the *Paris-Lyon-Méditerranée* (P.L.M.) which subject was the French Alps resort of Chamonix. Since then, the countryside, the sea or the mountains have been the principal subjects of posters created to promote tourism.

The timetable represented the first form of railway poster, both in Europe and in North America. Its standard format was the one used by the printing industry, and was ideal for use in newspapers and on the walls of railway stations. This type of advertisement illustrated the complexity of the early rail networks and their operations.

Any event could be used by the railway companies as an opportunity to advertise and promote their services. By offering reduced rates and all kinds of package deals, the railway companies were contributing to the democratization and popularity of tourism (which was in its infancy at that time) among all classes of the population.

Competition among the railway companies encouraged the creation of new services targeting different clientele. For example, one poster offered a reduced excursion fare, trying to reach the urban population through the use of an appropriate slogan. Excursions were the first form of tourism. In fact, both in Europe and in North America, people, with a few exceptions, were just discovering the areas surrounding their cities, something which was impossible before the advent of the railway.

COLONIZATION & IMMIGRATION (1880-1920)

Thanks to the Canadian government's gifts of lands, the railway companies also became important real estate owners. The use and development of the railway, with inherent revenues, was linked to the development and colonization of the country.

The railways were very interested in the recruitment of new immigrants. Some opened immigration offices and set up agencies across Europe and the United States. Many posters were created especially for these agencies, sometime in several languages, and advertised almost exclusively the merits of the Canadian West.

In Canada itself, agencies were set up to recruit new settlers for the West from the already established population. Different posters were created which targeted the "Eastern Canadian" and extolled the marvels of the West.

From 1885 to 1914, more than one million people chose Canada as their new country. The First World War and the subsequent crisis (both economic and politic) stopped the migratory flow. From then on immigration was taken over by the Canadian government which produced its own posters. After the Second World War, Canada experienced another boom in immigration, mostly due to geo-political disruptions in Europe. At that time the airlines - themselves creations of the railway companies - took over from boats and trains as the "normal" way to immigrate and travel.

Colonization was always the preoccupation of railways which wanted to make their operations profitable. Exploratory excursions were offered to attract farmers and labourers. These posters were distributed among the stations in all cities in Eastern Canada or the United States.

Railway companies had been important players in the migratory movement since the second half of the 19th century, both in Canada and in France. The latter was geographically well suited for emigration, with several ports which were terminals for some of the busiest sea lines, particularly from and to North America. Besides the Canadian posters used in France for the recruitment of immigrants, an important production of French posters promoted

L'horaire de train représente la première forme d'affiche ferroviaire. Son format standard d'imprimerie permet sa diffusion aussi bien dans les journaux que placardé à divers endroits. Il est intéressant de remarquer que ce type de publicité nous montre la complexité des réseaux et des opérations ferroviaires à leurs débuts.

Tout événement sert de prétexte aux compagnies ferroviaires, pour publiciser et exploiter leurs réseaux. Ainsi, en offrant une gamme de forfaits à prix réduits, ces compagnies contribuent à démocratiser et développer le tourisme des classes ouvrières.

La concurrence entre les compagnies ferroviaires favorise l'apparition de nouveaux services ciblant des clientèles différentes. Une affiche qui annonce à bas prix une excursion, tente de joindre par un slogan évocateur, une clientèle citadine. Par l'utilisation de slogans, les compagnies s'efforcent de créer un langage publicitaire plus efficace. Les excursions sont les premières formes de tourisme. En fait, en Europe comme en Amérique du Nord, les citadins découvrent les environs de leur lieu de résidence grâce au train. Il suffit de penser à la popularité du "P'tit Train du Nord" pour les skieurs excursionnistes, détrôné plus tard par l'automobile et les liaisons par autobus.

L'IMMIGRATION ET LA COLONISATION (1880-1920)

Grâce aux immenses territoires que le gouvernement canadien octroie de part et d'autres des voies ferrées, les compagnies ferroviaires se présentent comme d'importants propriétaires fonciers. L'usage du chemin de fer ainsi que les revenus qu'ils génèrent doivent trouver leur source dans le développement et le peuplement du pays.

Les compagnies portent donc une vive attention à la colonisation et au recrutement des nouveaux arrivants. Certaines compagnies ouvrent des départements d'immigration et mettent sur pied des agences de recrutement en Europe. Ces agences sont des lieux importants de diffusion d'affiches vantant, notamment dans plusieurs langues, les mérites de l'Ouest canadien.

De la même façon, au Canada, certaines de ces compagnies sont également chargées de toute la publicité entourant la colonisation.

La colonisation est au centre des préoccupations du pays et les compagnies ferroviaires en profitent. Elles offrent des visites exploratoires de courte durée dans le but d'attirer d'éventuels colons déjà établis ou des immigrants fraîchement débarqués sur le Continent. Ces affiches sont diffusées dans les gares et les villes de l'est du Canada et du Nord-Est des États-Unis.

Les compagnies ferroviaires françaises participent dès la fin du 19e siècle, à ce vaste phénomène migratoire. En effet, la France a la particularité géographique d'offrir de nombreux ports d'embarquement desservant plusieurs lignes maritimes canadiennes à destination de l'Amérique du Nord. Ainsi, en offrant des tarifs spéciaux, elles acheminent à cette époque de nombreux immigrants souvent peu fortunés venus des quatre coins de l'Europe.

Notons toutefois, que le tourisme est déjà à cette époque le sujet privilégié de l'affiche ferroviaire française. Alors que l'Amérique cherche à se peupler, l'Europe se découvre: la mer, la montagne et la campagne s'offrent au citadin.

LE TOURISME (1920-1939)

Entre 1920 et le début de la Seconde Guerre mondiale, les compagnies ferroviaires canadiennes érigent, afin de rentabiliser leurs réseaux, d'importantes infrastructures touristiques

Grand Trunk
 Railway
 of
 CANADA

The Great
INTERNATIONAL
 ROUTE
 between the
East & West

RAILWAY CANADA CO.

1888

QUEBEC AND
LAKE ST. JOHN
 RAILWAY

Only Rail Line
 Through The
LAURENTIDES
 Mountains
 The
 Canadian Adirondacks
LAKE ST. JOHN
 THE HOME OF THE CELEBRATED
DUANANICHE
 FRESH WATER SALMON

with your Primeval Saguenay

DAILY EXPRESS TRAINS
 AND
ELEGANT PARLOR & SLEEPING CARS
 CONNECTION WITH THE SAGUENAY STEAMERS
 UNSURPASSED HOTEL ACCOMMODATION
 AT ROBERVAL, LAKE ST. JOHN AND AT THE
 FISHING GROUNDS OF THE GRAND DISCHARGE.
 FOR FOLDERS AND OTHER INFORMATION APPLY TO
 ALL LEADING TICKET AGENTS IN THE
 UNITED STATES AND CANADA.

Alex. Hardy, Secy. & Pass. Agt. J.G. Scott, Secy & Manager.
 GENERAL OFFICES AND TERMINUS 160 ST. ANDREW ST. QUEBEC.

c. 1900

the emigration to France's new colonies in Africa and the Far East which were just beginning to develop. By offering reduced rates to these ports, the railways helped the migratory movement of millions of people, often poor or without work.

At the same time, Europe not being suited for immigration, was not looking for new people; quite the contrary. To help make the rail lines profitable, tourism was adopted and promoted much earlier than in North America.

TOURISM IN NORTH AMERICA (1920-1939)

Whereas French railways had promoted tourism since the 1880's, the Canadian railways had to wait until the end of the First World War to experience an explosion of interest in tourism. From 1920 until 1939, the Canadian railways invested heavily in their tourism infrastructures all over Canada. To attract an ever discriminating clientele, artists (and not simply typographers) were hired to create a new line of posters which were among the most important in the history for that medium.

These were distributed in Canada and elsewhere through tourism agencies and offices. Artists who created them, used new processes and printing techniques which helped enhance the appearance of the illustration, making it more "powerful", such as those many landscapes - stereotyped - depicting the Canadian Rockies, the Canadian Plains or any other part of the country.

Subsequently, under the influence of modern art currents, the artists hired by the railways rapidly designed a new graphism in which the interest for legibility was put to the service of a railway industry in full technological revolution.

This "golden age" of the railway poster, is characterized by a will to represent not only the means of transportation or the fares, but the destination, which, after all, was the product to sell, the train being only the means to reach it. Perfect and idealistic landscapes were typical of the production.

Some illustrators, such as Hal Ross Perrigard, wanted to animate the landscape. The posters produced during that period were typically "populated" by women which were thought to enhance the attractiveness of the place depicted.

Cassandre (whose real name was Adolphe Mouron), a French *affichiste* revolutionized the railway poster with the introduction of the machine which was, until 1925, almost entirely absent from the iconology. Following his influence, several artists, including Canadians, produced a new family of railway posters where the mighty locomotive, streamlined and gracious, yet monstrous in some way, appeared in all her beauty. Power, speed and confort were the new credo of the railway industry which begins to feel the rivalry of other means of transportation. This poster was typical of the production of the late 1930's.

Graphists and illustrators such as Norman Fraser, used serigraphy for the production of colourful and enlivened posters. This process, derived from the stencil technique, was adopted on an industrial scale during the 1930's. With it, it was possible to create powerful illustrations with large color applications.

With time, especially since the 1960's, poster composition was radically simplified. The railway poster now had to transmit clearly and powerfully a simple message, or slogan. The landscape slowly disappeared. Text, with new fonts and styles, was becoming important once again. In some way it represents a kind of return to the origins.

To make their operations profitable, the french railway companies tried as early as 1887 to improve the touristic infrastructures (Canadian companies had to wait until the 1920's). Thanks to these

pancanadiennes. Pour promouvoir leurs installations chez une clientèle en pleine expansion dans le monde, ces compagnies font appel à des artistes qui signent les affiches les plus marquantes de l'histoire de ce médium.

Ces affiches sont diffusées au Canada et à l'étranger dans des agences et des bureaux touristiques. Les artistes qui les créent utilisent des procédés d'impression nouveaux leur permettant une imagerie plus séduisante, tel que des paysages - aujourd'hui stéréotypés - illustrant les charmes du Canada.

Subséquentement, sous l'influence de divers courants artistiques modernes, ils s'appliquent très rapidement à façonner un graphisme dont le souci de lisibilité est mis au service d'une industrie ferroviaire en pleine révolution technologique.

Cet âge d'or de l'affiche ferroviaire est caractérisé par une volonté de représenter non pas les trajets ni le moyen de transport, mais plutôt la destination. Ces affiches attrayantes tentent de faire oublier les trajets et les itinéraires parfois ardues qui attendent les voyageurs à cette époque de la vapeur.

Certains illustrateurs, comme Hal Ross Perrigard, s'intéressent aux paysages animés. À cette époque, un tel paysage est plus attrayant lorsqu'on y rencontre une femme... Du moins est-ce l'opinion des publicistes en herbe qui associent la féminisation des sujets au raffinement et à la qualité de vie.

Tandis que le paysage demeure pendant plusieurs années une forme récurrente de la publicité ferroviaire, on commence à partir de la deuxième moitié des années 30, à s'intéresser à d'autres attraits promotionnels du chemin de fer. C'est sous l'impulsion d'idées artistiques modernes qu'on s'applique à représenter la puissance, la vitesse et la beauté de la machine.

Des graphistes et illustrateurs canadiens comme Norman Fraser ont recours à la sérigraphie pour la reproduction d'affiches vives et colorées. Ce procédé dérivé du pochoir est adapté industriellement au cours des années 30 et permet de créer par des grands aplats de couleurs, des illustrations accrochantes.

Avec le temps, les compositions des affiches subissent une épuration radicale. L'affiche doit dorénavant transmettre un message clair et précis de l'annonceur au public. On délaisse progressivement l'illustration de paysage pour intégrer du texte comme seul élément de la composition. Retour aux sources...le graphisme et la typographie se rejoignent.

Afin de rentabiliser leurs réseaux, les compagnies ferroviaires françaises tentent de développer, dès 1887, des infrastructures touristiques. Grâce à ces efforts apparaissent dans le paysage français les stations balnéaires, et les stations thermales. De plus la montagne, les monuments et les lieux de pèlerinage deviennent des invitations au voyage pour les citadins enfin libérés de leurs murs. On fait appel à des artistes aquarellistes qui produisent des affiches-paysage typiques de la Belle Époque.

Hugo Alési, affichiste français de renom, était extrêmement consciencieux et perfectionniste. Ce trait de caractère l'amena à ouvrir sa propre imprimerie afin de contrôler toutes les étapes de la fabrication. La rentabilité de ses opérations n'étant pas son principal souci, il mourut dans la misère, ruiné. Il reste un artiste important à qui l'on doit quelques-unes des plus belles affiches-paysage de la *Belle-Époque*. Chamonix, le sujet de cette affiche, est une station de ski de renommée mondiale. Cette dernière est due en bonne partie à la promotion qui en a été faite dès le début. En fait, Chamonix fut le sujet de la première affiche-paysage ferroviaire française.

efforts, a string of sea or ski resorts, even thermal spas, soon appeared all along the railway lines, from the Alps to the Mediterranean and the Atlantic.

Monuments and historic sites also served as pretexts for excursions or a few days' vacations. Aquarellists are hired for their skills and their production was typical of the *Belle Époque*.

THE WAR YEARS (1939-1945)

Canadian railways heavily contributed to the war effort. They constituted the main means of transportation for raw goods and military equipment and personnel. Several thousand employees from the railway companies fought in Europe or Asia, some in railway battalions, others as aviators, infantrymen or sailors. A large number were kept in the country, appropriately named the "home front", actively engaged in the production of tanks, rifles and ammunition.

The Second World War represented the apogee of the use of the railway as the main means of transportation for the population. But, these years were also poor for the production of posters. The only ones created were used for propaganda. Patriotism was the slogan of the hour. Financing the war effort was on the agenda, along with recycling.

At the beginning of the Second World War, before the occupation by German forces, the French railways produced posters like their Canadian counterparts. During the occupation (from 1940 to 1944), posters were produced for the benefit of German propaganda. The sacrifice of literally thousands of railwaymen, excuted as saboteurs by the Gestapo (German secret police) or killed in the process of the allied air campaign against the German army, is a fact often forgotten. After the *Libération* the posters were used to promote the reconstruction effort.

THE GOOD COMPANY (1950-1970)

The 1950's marked a decisive turn in the history and development of railways in Canada and elsewhere. Diesel locomotives were increasingly used by the railways, and the last steam engine was put in service in 1949 by the Canadian Pacific Railway in the Rockies. This engine, the 5935, is preserved at the Canadian Railway Museum at Delson/Saint-Constant.

The modernization of rolling stock was an attempt by the railway companies to win a losing battle against the automobile and the airplane. In fact, as a whole, the rolling stock (from locomotives to passenger cars) of all North American railways was in really bad shape following the abuse of the war years. Modern equipment, security, comfort and speed were the key to the advertisement campaigns.

Sadly, largely due to the popularity of radio and television after the Second World War, the poster lost ground as an elaborate means of communication. It was less and less used and today occupies a secondary role. It was no longer the work of artists of all kinds, but merely the work of graphic designers and advertisers. No more dreams, no more enchantment, the railway poster was living its last days. At the end of the 1960's, photography was predominant in the advertisement business. This was the *coup-de-grâce* to the plethora of artists and illustrators who were devoted to the production of fine posters of all kinds.

RAILWAY WORKERS

The railway industry has always been an important employer. In that sense, the history of the railway poster is a witness to the contribution made by the railway workers as principal actors in the development of this industry.

L'EFFORT DE GUERRE (1939-1945)

Les compagnies ferroviaires canadiennes contribuent largement à l'effort de guerre. En effet, les réseaux de chemin de fer constituent le moyen de transport essentiel pour diriger les soldats et les équipements militaires vers les ports canadiens où des navires partent à destination de l'Europe. De nombreuses personnes, à l'emploi de ces compagnies, s'enrôlent dans l'armée; d'autres travaillent pour une industrie qui se recycle, pour la durée du conflit, dans la production d'armement.

La deuxième guerre mondiale correspond à un ralentissement des activités publicitaires pour de nombreuses compagnies ferroviaires canadiennes. Néanmoins, elles produisent des affiches qui font appel à l'esprit patriotique des employés et des usagers dans le but avoué de soutenir l'effort de guerre en le finançant et en introduisant la notion de recyclage des matières premières.

La France présente un cas particulier. Au début de la guerre, sa production d'affiches ferroviaires est dans la même lignée que les autres pays. Cependant, pendant l'occupation allemande, la production d'affiches, quoique restreinte, fut mise au service de la propagande ennemie qui essaye de décourager les cheminots de soutenir la résistance. Le sacrifice de plusieurs milliers de ces derniers témoigne de l'échec de l'occupant nazi. Avec la *Libération* la production d'affiches ferroviaires s'orientera vers la reconstruction du pays en misant sur la fierté nationale.

LA BONNE COMPAGNIE (1950-1970)

Les années 50 marquent un tournant décisif dans l'histoire et le développement du chemin de fer au Canada soit le passage de la vapeur au diesel. Face à l'apparition de nouveaux modes de transports concurrents, comme l'avion et l'automobile, les compagnies ferroviaires misent sur cette révolution technologique pour attirer une clientèle de passagers qui tourne le dos à ses réseaux. Ce positionnement entraîne un renouvellement du message dans l'affiche ferroviaire.

C'est le moyen de transport plutôt que la destination qui prime maintenant dans la représentation du chemin de fer. Cette révolution technologique du diesel permet en effet d'introduire la notion de rapidité, de confort, de sécurité et de modernité. Parallèlement, le langage graphique se modernise, gagne en pureté, en efficacité.

Face à ce déclin du transport de passagers et à la concurrence de la publicité radiophonique et télévisée, l'affiche devient, à partir des années 60, un moyen publicitaire de moins en moins utilisé. Les beaux jours de l'affiche ferroviaire sont comptés... C'est vers la fin des années 60 que la photographie envahit le domaine de la publicité ferroviaire. La photo donne un coup de grâce aux artistes qui avaient auparavant dominé la création d'affiches illustrées.

LES EMPLOYÉS

L'industrie ferroviaire a toujours été un important employeur au Canada. Dans ce sens, l'histoire de l'affiche ferroviaire témoigne de la contribution et de l'affirmation des travailleurs du chemin de fer, comme principaux acteurs du développement de cette industrie au pays.

A Red Letter Day

For - Canada

June 28, '86

WHEN THE

CANADIAN PACIFIC RAILWAY

OPENS PACIFIC OCEAN

-TO THE-

TRAIN LEAVES DAILY:

Toronto,	- -	5.00 p.m.
<small>17 O'Clock</small>		
Montreal,	- -	8.00 "
<small>08 O'Clock</small>		
Ottawa,	- -	11.45 "
<small>EXCEPT SUNDAY</small>		<small>02.45 O'Clock</small>

OUR OWN LINE

FROM THE

ATLANTIC TO THE PACIFIC

NO CUSTOMS NO DELAYS NO TRANSFERS

LOW RATES QUICK TIME

For further particulars apply to any Agent of the Company, or to

W. D. HUGHES, <small>Traveling Passenger Agent</small>	W. R. CALLAWAY, <small>Traveling Passenger Agent</small>
<small>140 KING STREET WEST, TORONTO</small>	

W. C. VAN HORNE <small>Vice-President</small>	DEO. OLDS <small>Gen. Traffic Manager</small>	D. McNICOLL <small>General Pass. Agent</small>
MONTREAL		

Walter Ross, President, Toronto

SUMMER TOURS FOR 1893

Toronto TO Toronto Canadian Pacific Ry

AROUND THE WORLD \$610.00	AUSTRALIA & RETURN \$410.00	CHINA & RETURN \$447.50	HONOLULU & RETURN \$235.00	ALASKA & RETURN \$205.00	PORTLAND OREGON & RETURN \$110.00
JAPAN & RETURN \$410.00	WINNIPEG & RETURN \$50.00	HALIFAX & RETURN \$40.00	ST JOHN & RETURN \$35.00	BANFF & RETURN \$85.00	VICTORIA & RETURN \$110.00
DULUTH & RETURN \$32.00	BAR HARBOR & RETURN \$32.50	ST ANDREWS & RETURN \$31.00	PARTHUR & RETURN \$30.00	NEWPORT & RETURN \$20.00	ST PAUL & RETURN \$30.00
ST. LOUIS & RETURN \$29.50	INDIAN LAKE & RETURN \$26.00	PORTLAND & RETURN \$25.00	WHITE MOUNTAIN & RETURN \$24.00	W. D. HUGHES & RETURN \$23.00	CHICAGO & RETURN \$19.00

FROM OTHER POINTS PROPORTIONATE RATES.

GET A COPY FOR 1893 OF THE C.P.R. TOUR BOOK

"AROUND THE WORLD"	"FISHING & SHOOTING"
"HIGHWAY TO THE ORIENT"	BANFF & LAKES IN THE CLOUDS
"WESTWARD TO THE FAR EAST"	"TRIP TO ALASKA"

RETURN TICKETS

DOWN THE ST. LAWRENCE TO THE SEA TO THE MOUNTAINS TO THE GREAT LAKES

TORONTO TICKET OFFICE **1 KING ST. EAST** CORNER YONGE

D. McNICOLL, GENERAL PASSENGER AGENT, MONTREAL W. R. CALLAWAY, DISTRICT PASSENGER AGENT, TORONTO

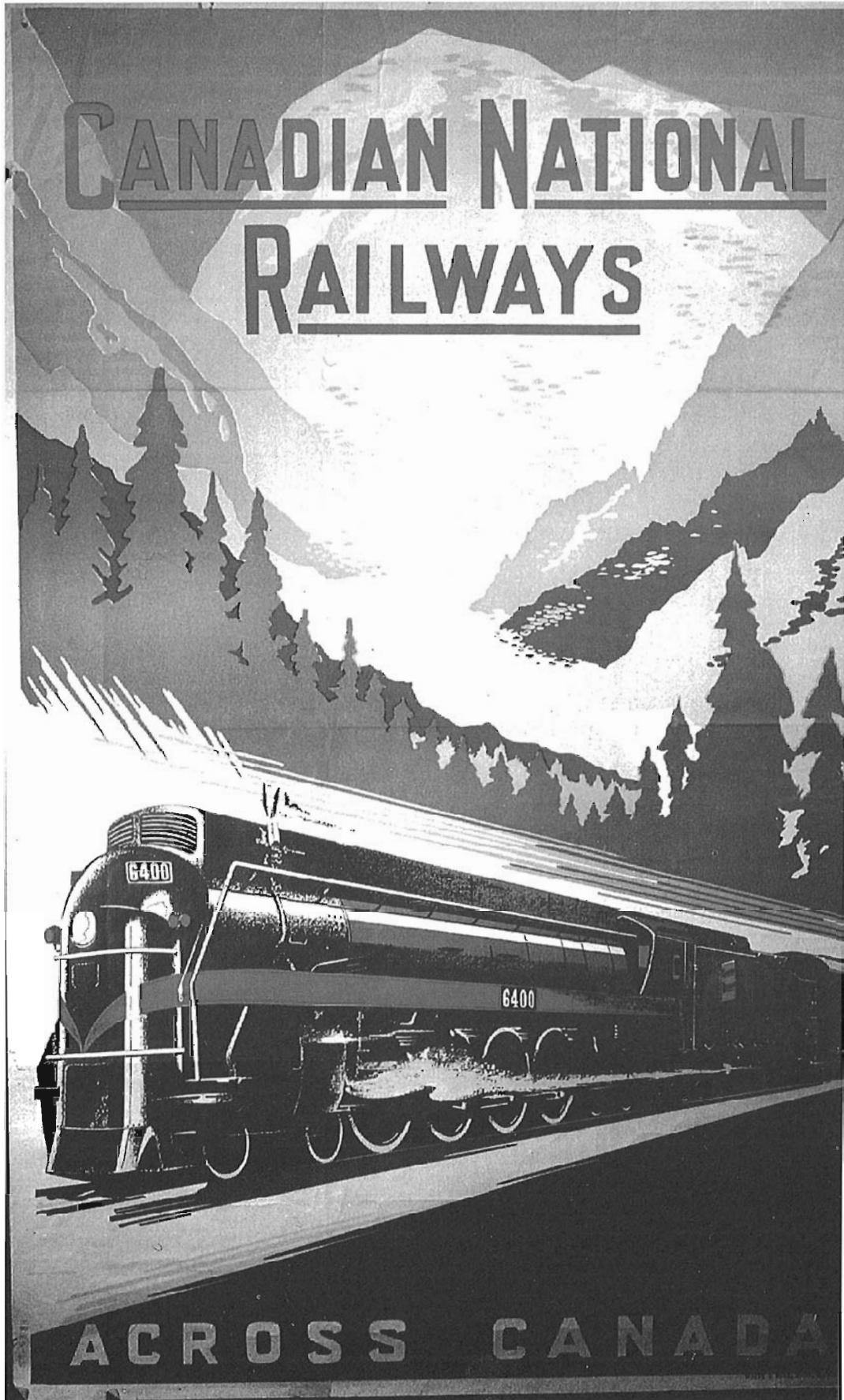

c. 1936

The First Consolidation Built in Canada

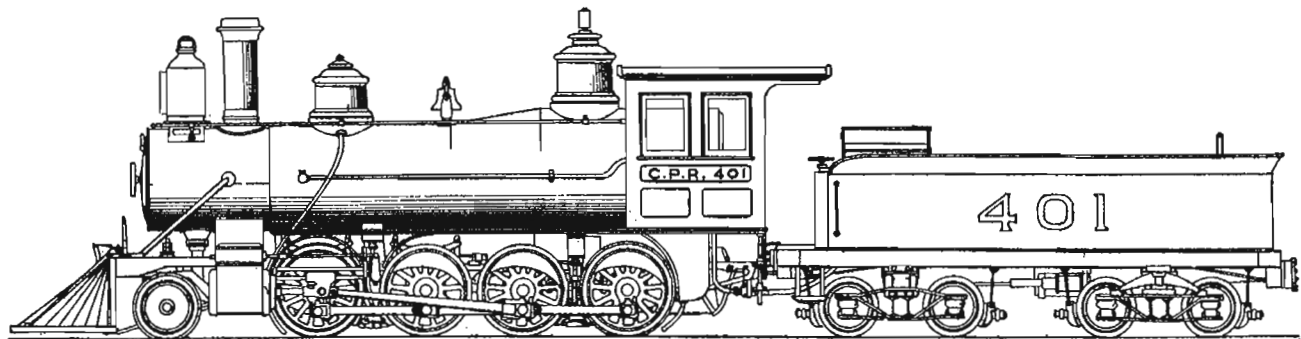

When one thinks of CPR locomotives of the 1880s, one tends to think of the ubiquitous 4-4-0, probably because they were so numerous, as well as the fact that the few survivors are all of that type. Here we will see what was then a much rarer type but was the forerunner of a wheel arrangement that was to become of great importance in freight service in the twentieth century.

On June 28, 1886 the first regularly scheduled CPR transcontinental passenger train departed from Montreal bound for Port Moody in British Columbia, which it reached six days later. After many years of planning and construction, the transcontinental railway was open at last.

In order to complete the railway through the mountains of British Columbia certain "Temporary" expedients had been employed. Most notable among these were the 4.4% grade on the "Big Hill" between Stephen and Field, and the series of loops over Rogers Pass. Although it was realized that these features would eventually be replaced, this would be an expensive proposition, and it would be more than a quarter century before this came to pass. Operation on the "Big Hill" was abandoned upon completion of the Spiral Tunnels in 1909, and trains ceased to go over Rogers Pass when the Connaught Tunnel was opened in 1916.

During the construction days, and for some time thereafter, most of CP's locomotives were of the 4-4-0 wheel arrangement, which was by far the most common type in use in North America at that time. On steep grades it was the practice to doublehead or triplehead 4-4-0s, and helper locomotives would be stationed near these grades. CP realized there would be problems operating on such grades and in 1884, even before the line was completed, ordered two 2-8-0s, known as the Consolidation type, especially for helper service on the "Big Hill". These were built by Baldwin, were numbered 312 and 313, and went into service late in 1884. Two years later they were followed by two similar locomotives, 314 and 315. These were entirely satisfactory and were used as intended for many years, the last one surviving until 1928.

The world's first 2-8-0 had been built by Baldwin in 1866 for the Lehigh Valley Railroad in Pennsylvania, and was intended for heavy freight service. At that time the Lehigh Valley was in the process of consolidating several smaller railroads into its system so, in commemoration of this, the new locomotive was named "Consolidation". Soon the name of this locomotive was applied to that particular wheel arrangement, and this name has been used ever since.

In 1883 the CPR constructed its new locomotive shops on Delorimier Avenue in Montreal and, under the direction of Mechanical Superintendent Francis R.F. Brown, began to build its own locomotives. Until 1888 most were 4-4-0s, and at least three of

these, greatly rebuilt, have survived. These are 351 (now 144), 374, and 391 (now 29). However other types were considered and some were constructed during the Brown era. For a short time 2-6-0s were being produced, but these were soon succeeded by the much more successful (for CP) 4-6-0s. In addition it was realized that the 2-8-0 wheel arrangement would be very useful for certain applications, as the 1884 Baldwins had proved. Although in later years the 2-8-0 would be built in very large numbers for CP (fully one sixth of its entire steam locomotive fleet) this situation was far in the future in the 1880s. So it was that in 1886 Brown designed a very handsome looking 2-8-0, named the S.D. class, and four of them were built and numbered 401 to 404. The following year two more almost identical locomotives, S.G. class 405 and 316 (later renumbered 406) joined the fleet. It is said that the 401 type were originally intended for freight service on the North Shore of Lake Superior, but in fact they were assigned to helper service over the Selkirks between Golden and Revelstoke B.C. For many years they served this line well, being used regularly on passenger trains as well as some freight service. Until at least the late 1890s they were a feature of this scenic part of the transcontinental run.

CPR number 401, the first of its series, was the first 2-8-0 to be built in Canada, and the first CP locomotive with the extended smokebox. It had builder's number 1048, and went into service in September 1886. The publication "The Railroad Gazette", in its issue of May 6, 1887, (exactly 110 years ago today as this is being written) had a full description of these new locomotives. This account, with its highly detailed drawings, is printed here in full. Two things are immediately apparent in studying the drawings. First is the amount of detail and fine work required on even these early and somewhat simpler locomotives of the 1880s. Secondly they show the superior draftsmanship practiced in those days, a skill that has become almost a lost art in these times of computer simulation and other drafting procedures. These drawings are so detailed that it would seem to be almost possible to use them to build a 2-8-0 of the 1880s! As is usual in our reproduction of old articles, the spelling and punctuation are exactly as written 110 years ago. The layout and size of the drawings have been changed to suit the format of Canadian Rail, and to make them a convenient scale for possible model making. The large plan and elevation drawings are scaled to 1/30 of actual size (2/5 inch to 1 foot), while the three cross-sections are to a scale of 1/24 (1/2 inch to 1 foot).

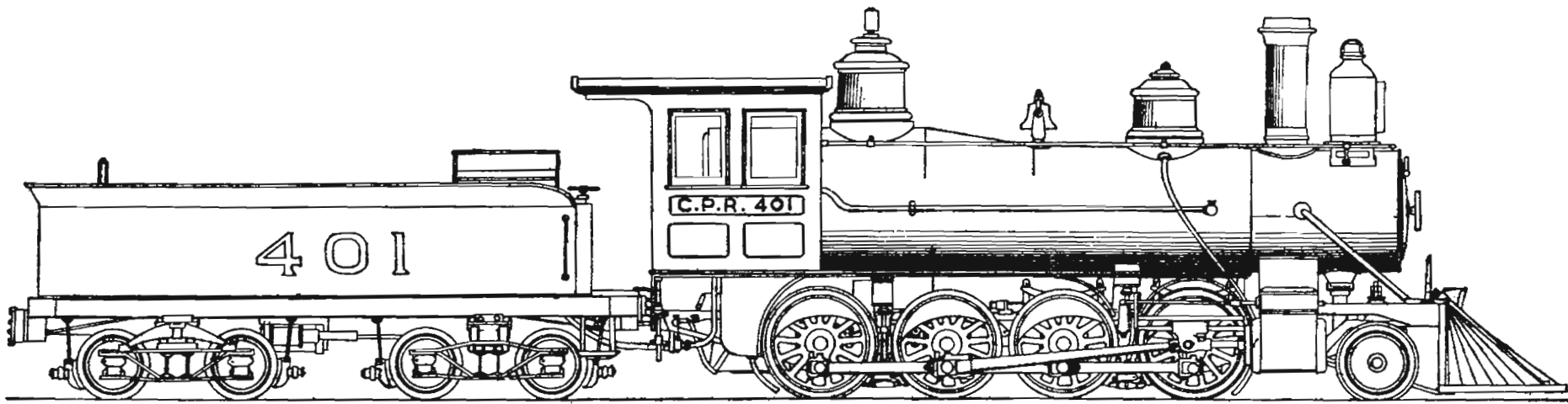
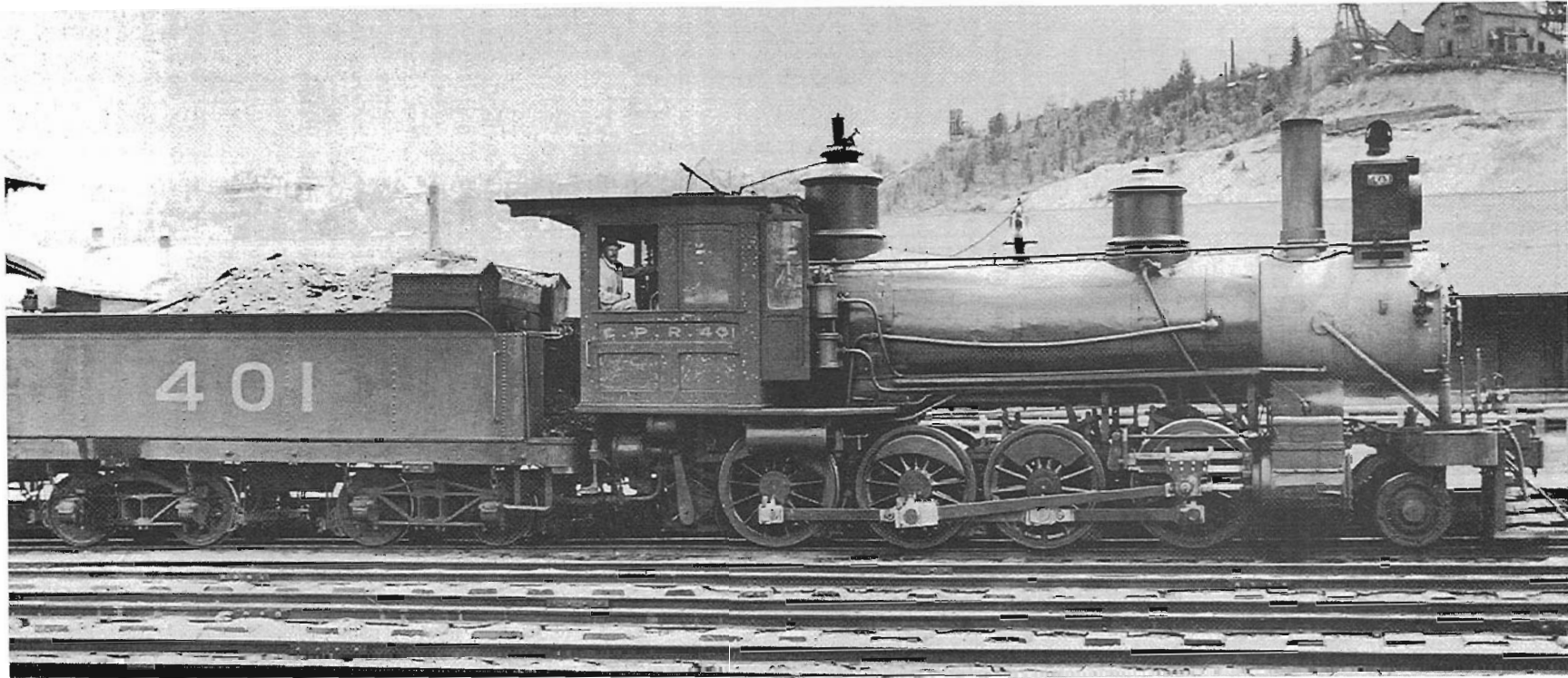

CONSOLIDATION LOCOMOTIVE AND TENDER—CANADIAN PACIFIC RAILWAY.

CONSOLIDATION ENGINE, CANADIAN PACIFIC RAILWAY

From The Railroad Gazette May 6, 1887

The accompanying illustrations show a class of consolidation engines, designed and built by Mr. F.R.F. Brown, Mechanical Superintendent of the Canadian Pacific Railway, at the shops of the company in Montreal. The engines are intended for working heavy freight service in the summer and to operate the passenger trains in emergencies in severe winter weather. These engines are the first consolidation engines built in Canada.

The principal features which distinguish these engines are the short stroke, 22 in., and the high boiler pressure, 160 lbs. per square inch, together with the large grate surface required to maintain that pressure. The weight of the engine is sufficient to almost entirely prevent slipping of the wheels in good weather without the use of sand, thus saving the wear of tires and machinery, the designer being of the opinion that a clean rail is much superior to a sanded one, though sand boxes are provided both front and back, for emergencies in bad weather. The fixed wheel-base is extremely short for the diameter of the driving wheels, and the counterbalancing is carefully estimated, the result being that the engine can be run at high speeds and on curved roads with a remarkable degree of ease and steadiness.

The frames are forged solid from the back end to front of leading drivers, and the upper and lower bars of front end, which embrace the cylinders, are connected to main frame by spliced and keyed joints, not by butt ends depending upon bolts for strength. Both these bars are extended to the back of the buffer beam, being there keyed and bolted together, and to the heavy smoke-box stay, the upper bar being checked on top for a heavy cross plate laid on flat. All are rigidly secured to the buffer beam and frames by "boxed" angle irons, thus forming an efficient protection to the cylinders in case of collision.

The back ends of the frames are secured by heavy cross-bars checked for and into the upper and lower edges of the frames. The cross-bars carry the drag-box, wedge casting and safety chains for tender, and extend outwards to support the cab back castings. The middle portions of the frame are stayed entirely independent of the boiler, and in such a manner as to prevent any twisting due to superincumbent weight.

The fire-box is spread over the frames and is supported by four cast-steel slippers on top of the

frames. The common system of carrying the fire-box by four side links has given trouble by springing the sides and corners of the foundation ring. Two heavy plates studded on the sides of the outside fire-box and bent under the top bar of the frame, together with two heavy links connecting brackets on the back face of the box to the frame form sufficient security for the boiler in event of derailment, but they carry no weight and admit of free expansion of the boiler.

The grate is rocked in two halves by separate handles on face sheet, and the dump can be worked easily by one hand from the footplate.

The ash pan is constructed in sections, so as to be easily removed without taking down any other part but the dump shaft, thus enabling any repairs to be made without taking the wheels out. Both ash pan and grate carriers are rigidly secured to foundation ring only, and not to fire-box sheets or frame in any way.

The boiler plates are all Siemens-Martin mild steel of fire-box quality, imported from Scotland, and are sheared, punched and riveted by Tweddell's hydraulic machinery, with steel rivets and stays of extra mild quality. The whole boiler is thus, with the exception of the foundation ring and one or two minor items, of steel of similar quality.

The valves are of the Allen type, with Morse balancing device, and the truck wheels are wrought-iron disks, made by Krupp, with Mansell clippings and crucible steel tires.

U.S. metallic packing is used for the piston rods and valve stems.

The engine is capable of exerting a tractive force of 155.7 lbs. per lb. pressure on pistons.

It is equipped with the Westinghouse automatic brake on the two forward pairs of drivers, and with the American steam brake on the two hind pairs, both systems being connected to the tender and intended to be used alternately.

Boiler, dome, cylinders, steam chests and saddle are covered with asbestos cloth $\frac{1}{2}$ in. thick.

Feed water is supplied by two lifting injectors, one No. 8 on right hand and one No. 9 on left.

Sight feed lubricators are used.

[A list of the principal dimensions follows on pages 72 and 73].

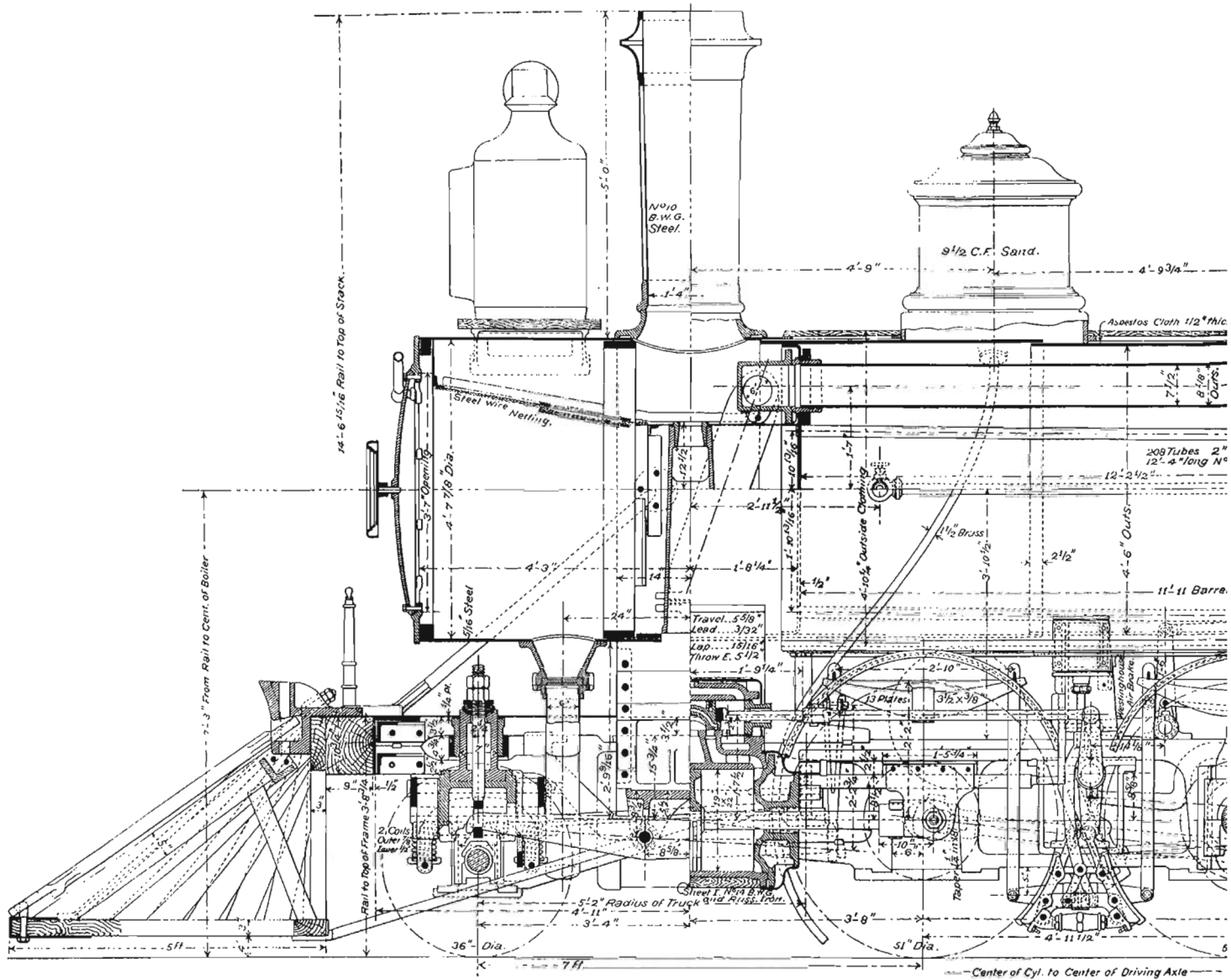

CONSOLIDATION LOCOMOTIVE,—

Designed by MR. FRANCIS R. F. BROWN, Mechanical Superin

MAY 6, 1887

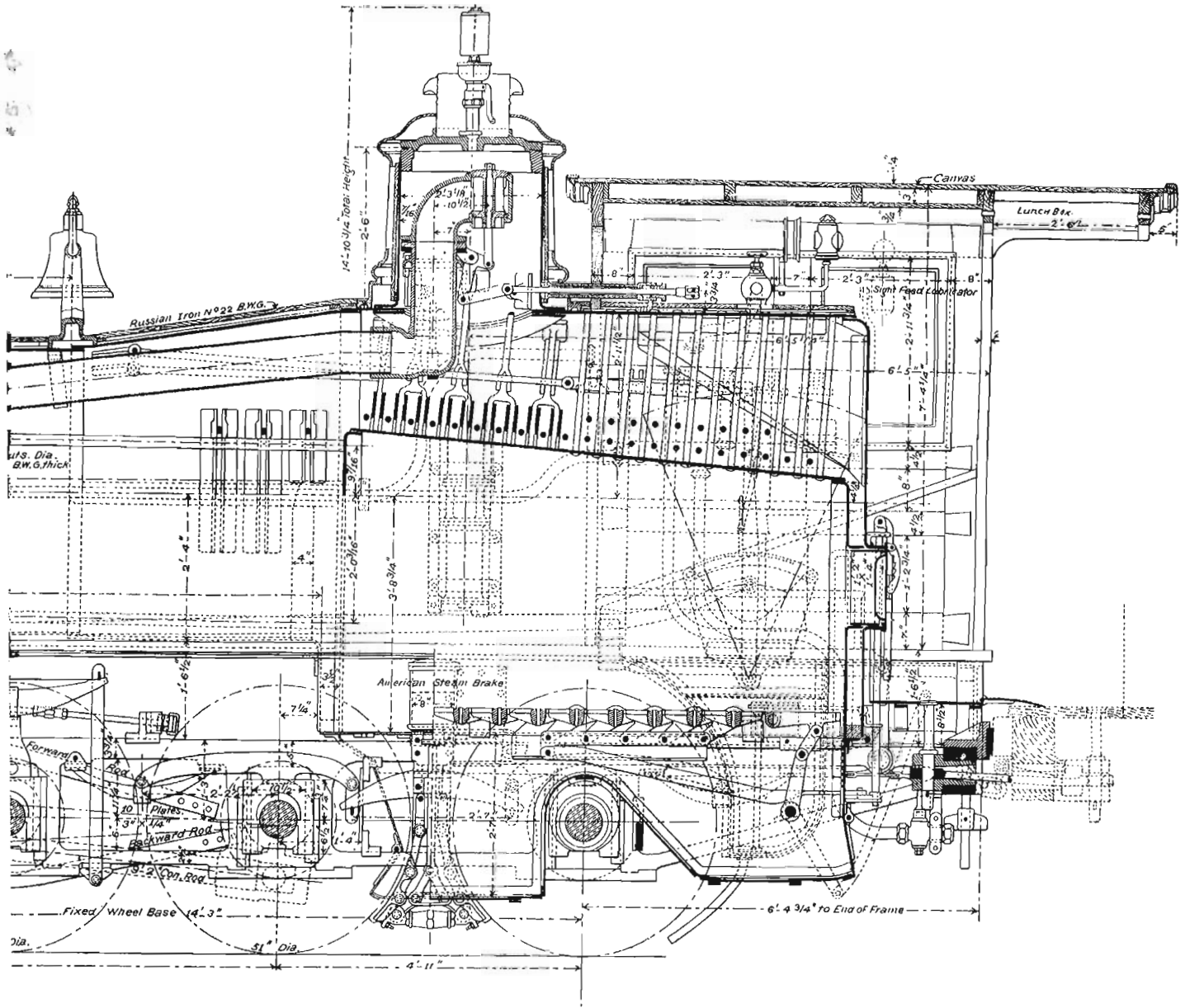

CANADIAN PACIFIC RAILROAD.

Ident. Built at the Company's Shops, Montreal.

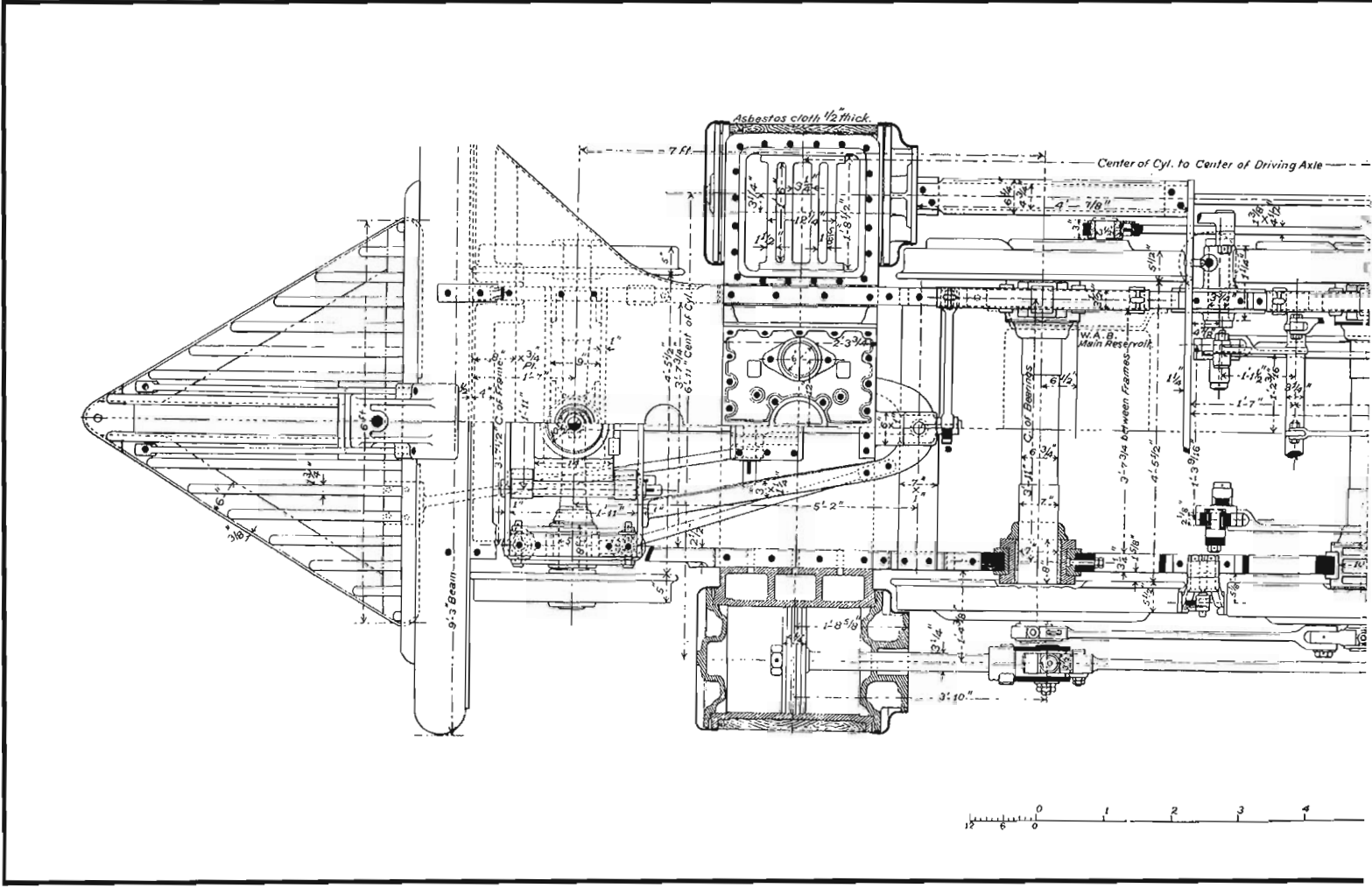

PRINCIPAL SPECIFICATIONS, C.P.R. CONSOLIDATION ENGINE 401. MAY 6, 1887

CYLINDERS AND MOTION

- Diameter and stroke..... 19 in. X 22 in.
- Distance apart of centres..... 6 ft. 11 in.
- Steam ports, length and width..... 18 in. X 1 5/8 in.
- Exhaust ports, length and width..... 18 in. X 3 ~ in.
- Diameter of piston rods..... 3 ~ in.
- Length of connecting rod..... 9 ft. 2 in.
- Journal of connect'g rod,
length and diameter..... 5 in. X 4 ° in.
- Travel of valve..... 5 5/8 in.
- Throw of eccentrics..... 5 ° in.
- Lap of valve..... 15/16 in.
- Lead of valve each opening..... 2/32 in. (sic).

WHEELS AND FRAME

- Driving wheels, diameter..... 4 ft. 3 in.
- Driving wheels, tires, width and thickness,
1st and 4th..... 5 ° in X 3 in.
flanged.
- Driving wheels, tires, width and thickness,
2nd and 3rd..... 6 in. X 3 in.
plain.
- Driving axle journals,
diameter and length..... 7 in. X 8 in.
- Truck wheels, diameter..... 36 in.
- Truck wheels, tires, width and thickness... 5 in X 2 ° in.
- Truck axle journals, diameter and length... 5 in. X 8 in.
- Fixed wheel base..... 14 ft. 3 in.
- Total wheel base of engine..... 21 ft. 3 in.
- Thickness of frames..... 3 ~ in.
- Width over frames..... 4 ft. 2 ~ in.
- Width between tires..... 4 ft. 5 ° in.
- Centre of cylinder to centre of driving axle. 13 ft. 0 in.

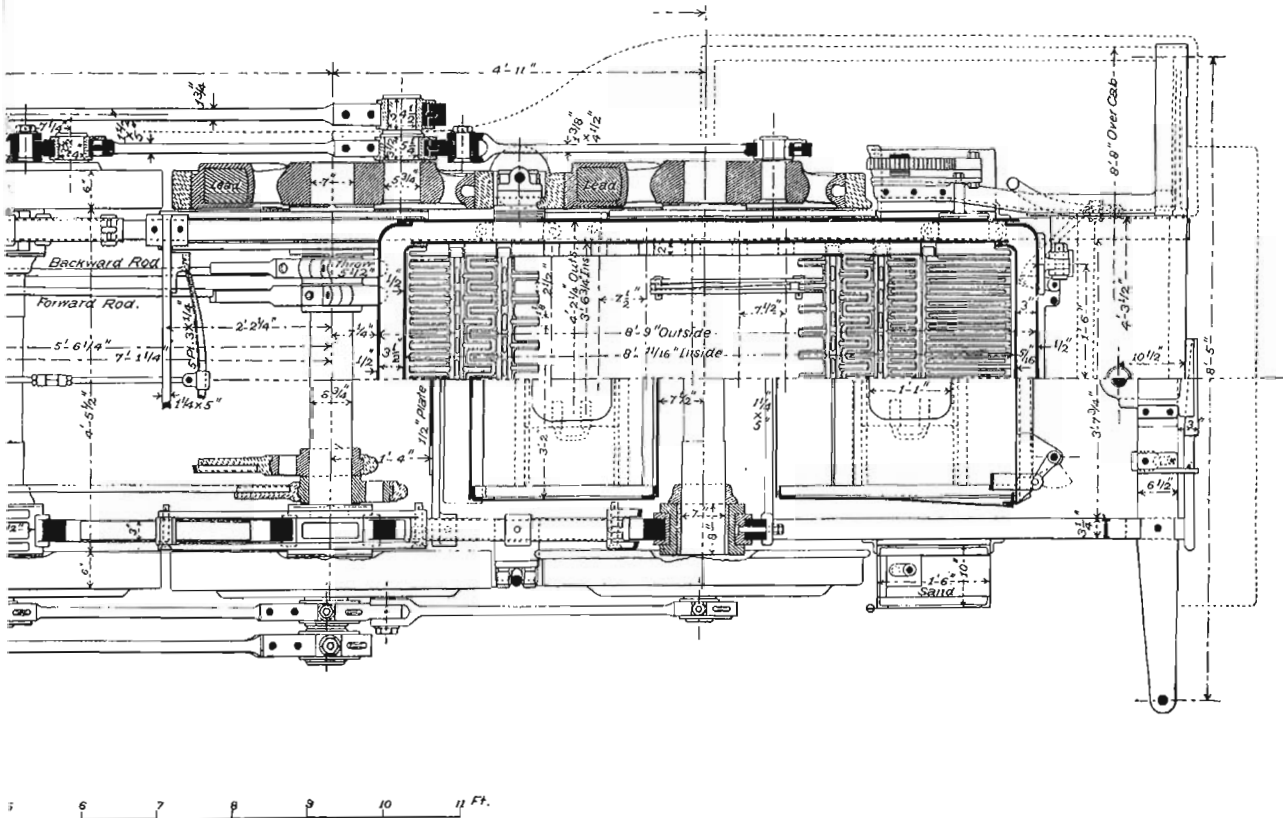

BOILER

Length of barrel.....	11 ft. 11 in.
Diameter of smallest course outside.....	4 ft. 6 in.
Thickness of plates.....	7/16 in.
Thickness of tube plates.....	° in.
Fire-box shell, sides, thickness.....	7/16 in.
Fire-box shell, back and top, thickness.....	° in.
Fire-box inside crown, thickness.....	3/8 in.
Fire-box sides and back, thickness.....	5/16 in.
Fire-box length.....	8 ft. 11/16 in.
Fire-box width, bottom.....	3 ft. 6 1/2 in.
Fire-box width, top.....	3 ft. 9 in.
Fire-box outside length.....	8 ft. 9 in.
Fire-box outside width, bottom.....	4 ft 2 ~ in.
Fire-box total depth inside, front.....	4 ft. 9 in.
Fire-box total depth inside, back.....	4 ft. 1 in.
Number of tubes.....	208.
External diameter of tubes.....	2 in.
Length between tube plates.....	12 ft. 2 ° in.
Heating service, tubes.....	1329 sq. ft.
Heating surface, fire-box.....	119 sq. ft.
Total heating service.....	1448 sq. ft.
Grate area.....	28.7 sq. ft.

WEIGHT AND CAPACITY

Weight in working order, on trucks.....	13,100 lbs.
Weight in working order, on drivers.....	90,900 lbs.
Total weight.....	104,000 lbs.
Weight of tender, empty.....	35,000 lbs.
Capacity of tender, coal.....	10 tons.
Capacity of tender, water.....	3000 imp. gallons or 3600 Amer. Gals.

Tender fitted with 33 in. Krupp wrought-iron steel tired wheels.



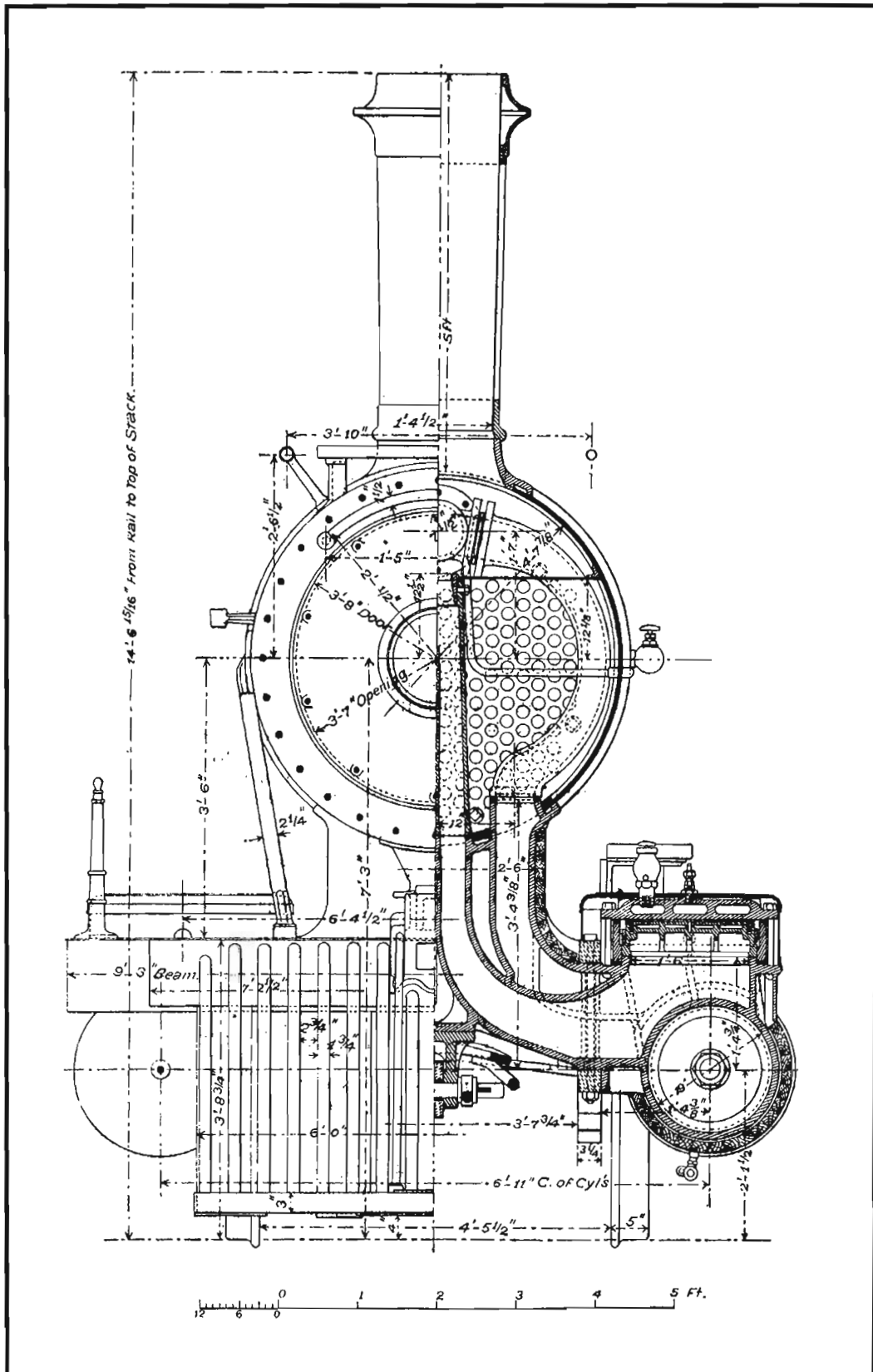

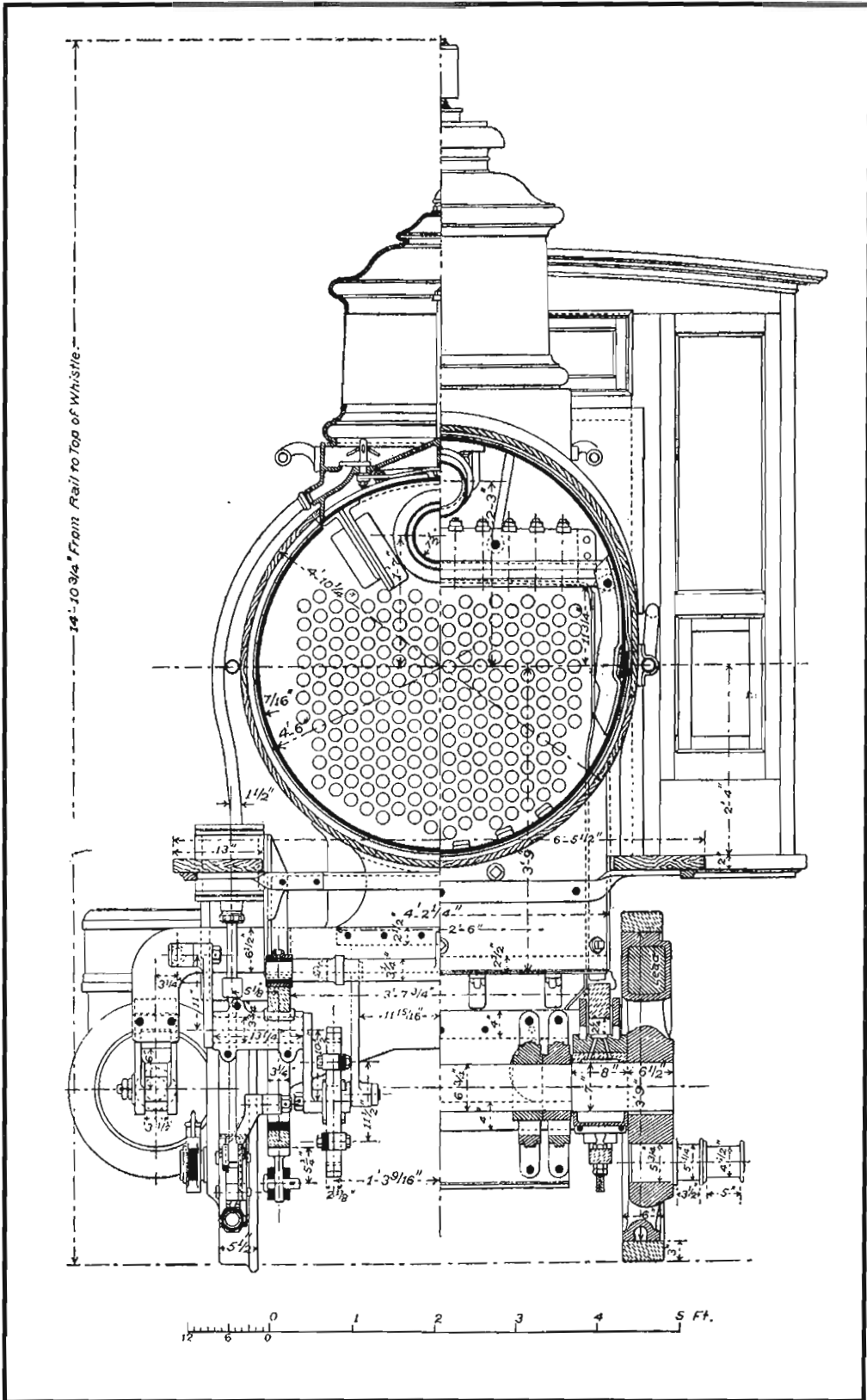

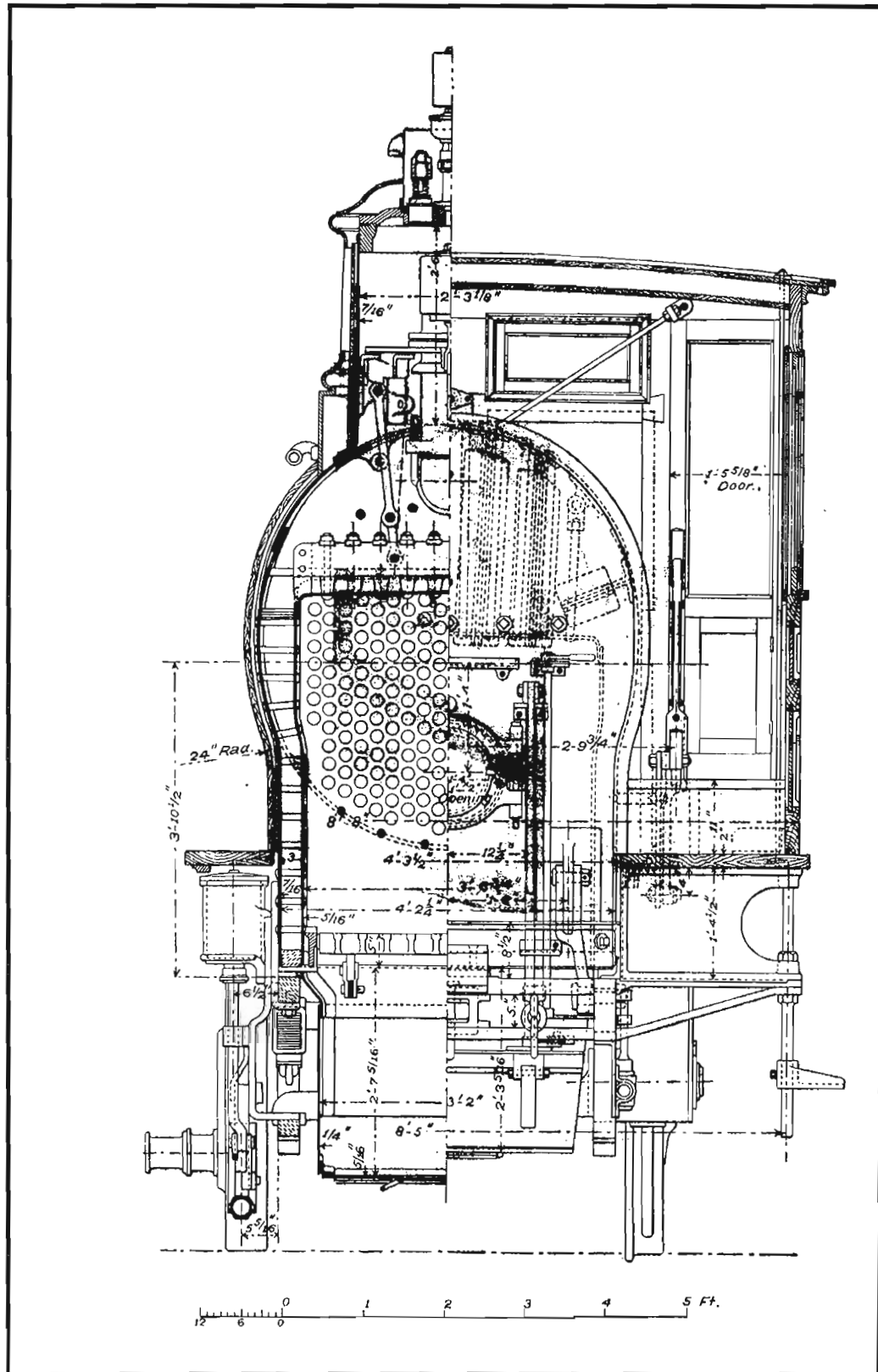

DETAILS OF COSTS AND SPECIFICATIONS OF MATERIALS FOR CPR LOCOMOTIVES

By Francis R.F. Brown. Mechanical Superintendent, C.P.R.

Extracted from a paper read before the Institution of Mechanical Engineers, London England, on May 16, 1887. From The Railroad Gazette, June 17, 1887.

(Note: Amounts of money were in pounds Sterling. These have been converted to dollars at the rate in effect in 1887).

In order to get the traffic through, it is considered of more importance that the engines should haul the largest possible loads with such economy as can be obtained, than that they should haul smaller loads at a cheaper rate per ton in regard to fuel. The passenger service on main lines is more often a combination of express and local than either one of these chiefly. Thus the majority of through express trains have to stop at nearly all stations either by time-table or by signal. Special care is therefore required in designing the engines so as to combine free running with the quickest possible starting power; and a continuous brake is also rendered necessary as well as expedient for economizing time in stopping.....

A batch of five engines of the S.A. class [4-4-0] which the writer has recently completed, cost, without extras, \$5205 each for the finished engine and tender.... The cost here given by the writer, being less than half that of an equivalent English engine, may be regarded with some surprise, and a few leading details will therefore be added. This cost includes all the coal used in the forge, blacksmith's boiler, and other shops, as well as all small tools and supplies used in the construction of the engines, such as brooms, brushes, candles, chisels, files, hammers, handles for tools, hemp, oil, waste, sand paper, tallow, wrenches etc.; also a complete set of tools of all sorts, lamps, oil cans, jacks, dogs and wedges, fire-irons etc., for the equipment of the engine in running order. But it does not include the salaries of foremen, draughtsmen and clerks, repairs to machinery, maintenance of buildings, water or coal used in the stationary boilers required for running the shop engine.....

Detailed Costs:—With regard to the detailed cost of certain portions of finished work for these engines, the forged frames cost 4 cents per lb., including scrap (charged at market value) and all coal; when planed, drilled and slotted all ready for erecting, the frames cost 5 1/3 cents per lb. The finished boiler ready to go into the frames costs 8 cents per lb., the steel plates having to be imported from Scotland, and freight and duty paid. The total cost of cylinders, fitted with covers, studded, and ready for erecting, is 5 7/8 cents per lb., and as the shops do not include a foundry, 4 cents per lb. has to be paid for the cylinder castings. The cast-iron driving-wheel centres cost 2 1/2 cents per lb., including cost of freight for over 400 miles. Connecting-rods and side-rods, fixed up with brasses, cotters, etc., all ready for use, cost 15 cents per lb.

The writer has lately built ten engines of the S.A. class and eight of the S.C. class, all of which are sent across the continent and are running between the Rocky Mountains and the terminus on the Pacific Ocean. Appended is a specification of the tests prescribed for materials used in the construction of locomotives built for the Canadian Pacific Railway.

Boiler Iron:—All boiler iron to be best quality Lowmoor, Bowling, or Krupp. A careful examination to be made of every sheet, and none to be accepted that shows mechanical defects. In every boiler one sheet to be ordered 3 in. longer than the size required, from which a strip is to be cut and tested. The piece so tested must have an ultimate tensile strength with the grain of not less

than 50,000 lbs. per square inch, an ultimate tensile strength across the grain of not less than 45,000 lbs., and must show a ductility, measured by elongation or reduction of area, of not less than 20 percent. Should any of the test pieces fail to fulfill the above requirements, the entire boiler may be rejected. Should any plates develop defect in working, they must be rejected. Each plate must be stamped with the maker's name.

Boiler and Fire-box Steel:—A careful examination to be made of every sheet, and none to be accepted that shows mechanical defects. A test strip from each sheet, taken lengthwise of the sheet without annealing, should have a tensile strength of 55,000 lbs. per square inch, and an elongation of 30 percent in an original length of 2 in. Sheets are not to be accepted if the test shows a tensile strength less than 50,000 lbs., or greater than 65,000 lbs. per square inch, nor if the elongation falls below 25 percent. Should any sheets develop defects in working, they must be rejected.

Iron and Steel Stay Bolts and Boiler Braces:—Iron or steel for stay bolts and braces must have an ultimate tensile strength of not more than 60,000 lbs., nor less than 48,000 lbs. per square inch, with an elongation of not less than 20 percent., and a reduction of area of fractured section of not more than 35 percent. It must also withstand the following test: A piece of iron or steel from 18 in. to 24 in. in length is to have one end fastened in a vise; over the other end a piece of pipe is to be passed to within 6 in. of the vise. By means of the pipe the sample must be bent until the end is at right angles to the portion in the vise, and then bent back to its original position. This must be repeated not less than twelve times without showing fracture, the bending being each time in the opposite direction to that previous.

Boiler Tubes of Steel or Iron:—All boiler tubes must be carefully inspected and be free from pit-holes or other imperfections. They must be rolled accurately to the gauge required. They must be expanded in the boiler without crack or flaw. When tested, iron or steel tubes must show a tensile strength of not less than 55,000 lbs. per square inch, and a ductility of not less than 15 percent.

Tubes of Brass or Copper; Brass and Copper Pipes:—Tubes of brass or copper to be of uniform circumferential thickness and solid drawn; to be perfectly round. A piece 30 in. long, annealed and filled with resin, must withstand being doubled until the extremities touch each other without showing defects. A piece 30 in. long, not annealed, filled with resin and placed on supports 20 in. apart, must withstand bending to a deflection of 3 in. without showing defects.

Bar Iron:—All bar iron (flats, rounds and squares) must be capable of sustaining an ultimate tensile stress of 50,000 lbs. per square inch, with an elastic limit of 25,000 lbs., and a minimum ductility, measured by elongation or reduction of area, of 20 percent.....

During the subsequent discussion, a Mr. Greig stated that for bad roads and for the circumstances under which the locomotives worked, those used on the Canadian Pacific Railway were much better adapted than any English engine that ever was made or ever would be.

SOME VIEWS OF THE CONSOLIDATIONS IN ACTION

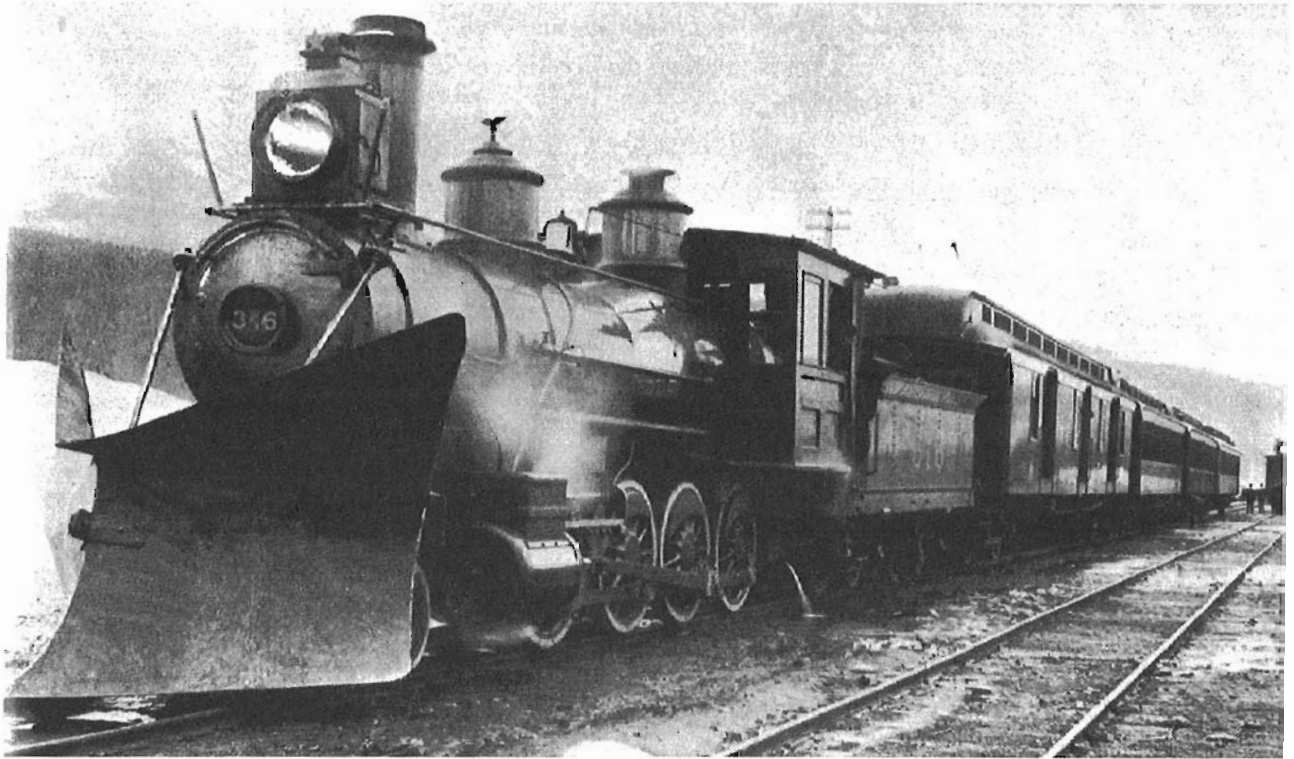

ABOVE: 316, later renumbered 406, was built in 1888, and here seen, about 1890, in winter passenger service with a huge plow. It was almost identical to 401, the major difference being the stroke of 24 inches instead of 22. It survived, as 3122, until 1927 when it was sold; the last survivor of the group.

RIGHT: 405 was virtually identical to 316 and was also built in 1888. It later became 3104 and was scrapped in 1920. This view was taken sometime in the 1890s.

BELOW: 402, also sporting a huge plow is shown on a passenger train about 1889. It was scrapped in 1907.

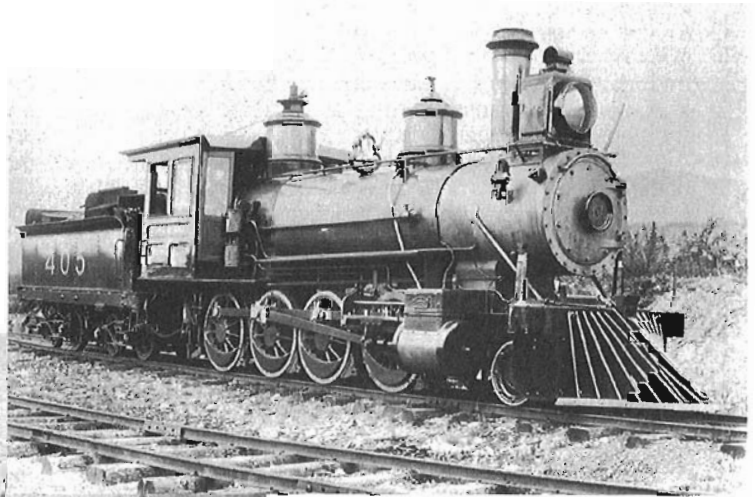

OPPOSITE, TOP: On the original Stoney Creek bridge, 401 hauls the eastbound trans-continental passenger train about 1889.

OPPOSITE, BOTTOM: Although of somewhat indifferent quality, this spectacular photo shows a C.P. Consolidation, perhaps 401 itself, hauling the westbound Pacific Express across the new steel Stoney Creek bridge in 1898. This spot has always been a favourite for publicity photos; these two are early examples taken at this well known location.

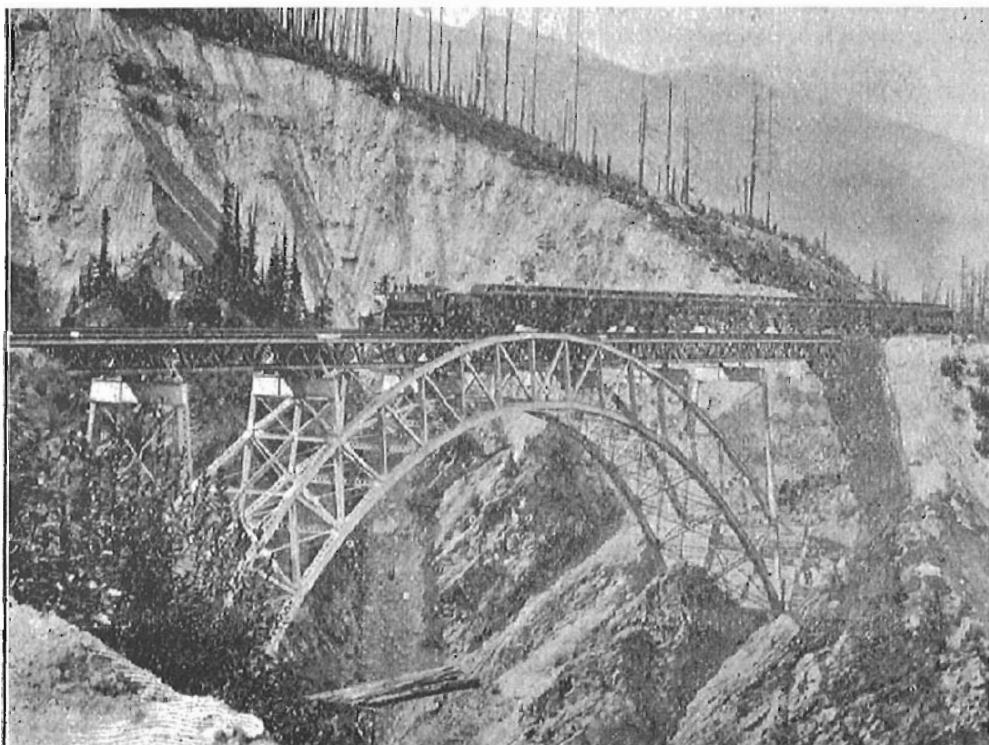
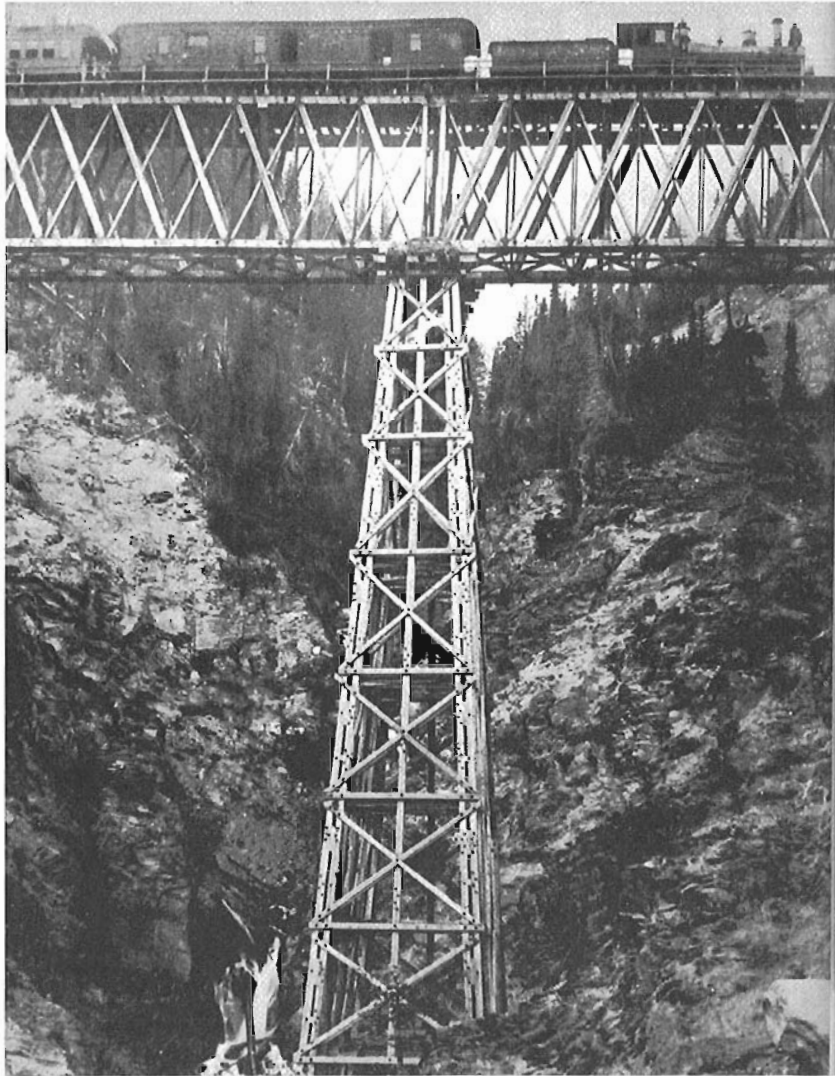

CONCLUSION

The Consolidations of the 1880s were the first of a long line. By the turn of the century, the CPR was building many 2-8-0s, mainly for freight service. Eventually there would be a total of 547 locomotives of this wheel arrangement built for CP lines, almost 17% of all CP steam locomotives.

Canadian National Railways had even more Consolidations, there being a grand total of 852, more than 20% of CN's total steam fleet. On both CP and CN, 2-8-0s remained in service until almost the end of all steam operation.

All of the original class S.D. Consolidations survived into the twentieth century, although by then they had been downgraded to branch line service. 402 and 404 were scrapped in 1907, while 401 and 403 were renumbered 1300 and 1302 in July and December of that year. At the same time they were reclassified L1a. 1302 (ex-403) did not last much longer, being scrapped in November 1909. Locomotive 1300 (ex-401, the subject of our story), however, had a career of thirty-five years. In February 1913 it became 3100 (not to be confused with the later 3100, a 4-8-4), still retaining classification L1a. It continued in service until 1922 when it was retired and scrapped in March of that year.

To bring the story to its logical conclusion, we will consider what happened to the very similar S.G.s, 405 and 406. In 1907 they became 1304 and 1322, class L1b and L2d, respectively. Then in September 1912, 1322 became 3122, while in February 1913, 1304 became 3104. 3104 was scrapped in July 1920, while 3122 was sold to the Manitoba & Saskatchewan Coal Company in March 1927. It was the last of the group to go.

So ended the careers of these pioneer locomotives which, though few in number, were the precursors of many more of that type in later years.

Sixty Years of C.R.H.A. Publications

By Fred F. Angus

When the CRHA was founded in 1932, its stated objectives were the collection, preservation and dissemination of artifacts and information relating to the history of railways in Canada. In order to disseminate information, the most efficient way, then as now has been by means of publications, either in the form of monographs or periodicals. The immediate aim of the Association in its earliest years was to organize suitable commemorative events for the 100th anniversary of the opening of the Champlain and St. Lawrence Rail Road on July 21, 1836. These events did, indeed, take place, and the official commemoration occurred on schedule on July 21, 1936.

Once the 1936 celebrations were over, the objects of the Association returned to its more basic aims, as originally envisioned. It was then felt that it was time to start a periodical which would contain articles of permanent historical interest to the student of Canadian railway history. So it was that, in April, 1937 the first issue of "The Bulletin of the Canadian Railroad Historical Association" first saw the light of day. It was a small publication, five pages of 8" by 11 sheets, printed on one side only on a mimeograph machine. Circulation was about 75. The editor was a young university student named Robert V.V. Nicholls, who was a charter member, the 17th to join the Association when it was founded in 1932. Happily, Dr. Nicholls, now Honorary President of the Association, is still with us, and is still an active director of the CRHA. One cannot help but recall that exactly 100 years ago the then British Empire celebrated the Diamond Jubilee of the reign of Queen Victoria. Today our publications are, in a small way, having a diamond jubilee of their own.

The very first page of the first issue was an editorial by John Loye, the Association's founder and President. This historic page is reproduced, in exact facsimile, on the opposite page. It deserves to be studied thoroughly, for the aims stated therein apply just as much today as they did sixty years ago. Its most important feature is the true statement that the strength of the Association is the sum of the individual talents of each of its members, and by exchanging information (what would today be called "networking", a term unknown in 1937) the compilation of a valuable record of Canadian railway history would be achieved. One interesting point is the proposal to include the study of aerial transportation as well. This has not yet occurred, but who knows what may happen in the future.

In the second issue (August, 1937) an article by Mr. Nicholls told the story of how the publication was started. The following is from that article: "*The first number of the Bulletin of the Association appeared in April, 1937. It was frankly experimental in nature. The fact that it was favourably received and that it appears to be firmly seated among the activities of the Association would seem to make it desirable for the Chairman of the Editorial Committee to offer to the members a statement of its policy. Since the birth of the Association in the Spring of 1932, the desirability, even necessity, of issuing a bulletin has been apparent to all. It was rightly expected that it would serve to preserve lectures, articles, and reports of the society's activities, and to contact members unable from dis-*

tance, or other reasons, to attend the regular meetings. The Railway and Locomotive Historical Society, after which our Association is patterned, has published a bulletin since 1921, one year after its founding [It still does. Ed.]. However, it was not until this year that we have been able to follow suit. In February, the Secretary reported that a mimeograph was available, and in March he was authorised to prepare the first issue, which would form a basis for discussion. Bulletin No. 1 appeared a month later. It was found acceptable and at the May meeting he was chosen to head a three-man Editorial Committee. The Committee was voted funds for the first year [The amount was \$20!. Ed.]. It is planned that the Bulletin will appear four times a year, probably in February, June, September, and December. For the present its size will be confined to six or eight pages, and the circulation to about seventy-five".

The first issue contained a very interesting review of the Association's activities during the commemorative year of 1936. It shows that, even in these early days, the CRHA was an active dynamic association. Starting with the second issue the Bulletin included historical articles as well as Association news. The very first of these articles is an account, by W.M. Spriggs, of "The Broad Gauge and the Great Western Railway". This article shows the fine research into Canadian railway history that was being done so early in the CRHA's history. It is proposed to reprint this article in Canadian Rail later this year as part of the 60th anniversary commemoration.

The earliest issues of the Bulletin had a simple title page with the name and place typewritten. Starting with issue No. 6, August 1938, a more elaborate masthead was adopted containing a larger rendition of the name, as well as the Association's insignia. This, the first real "masthead", is reproduced on the back cover of this issue.

The Bulletin continued to improve from issue to issue. Altogether this first run comprised 15 numbers with a total of 112 pages. Many significant articles appeared, at least two of which had maps. An interesting item which appeared in Bulletin No. 12, February 1940, included the financial statement for the production of the magazine in 1939. Total income was 26 memberships at 50 cents each plus stencils on hand worth \$2.30, a total of \$15.30. Expenses were \$8.49 for stencils, \$3.30 for 3000 sheets of paper, \$7.00 for typing, \$4.55 for postage and \$6.00 for the use of the mimeograph, for a total of \$29.34. This produced a loss of \$14.04 for the year which was covered by a grant. The present budget for Canadian Rail is about 700 times as much!

Alas, trouble was not only on the horizon; it was right here. By December 1940 Canada had been at war for well over a year and, although it received scant mention in the Bulletin, the effects of the war were universal. Many CRHA members, including the editor, joined the forces, and Bulletin No. 15, December 1940, was the last "for the duration". On the last page was mention of an effort by the Association to ensure the preservation of the locomotive "Duchess", then in the Yukon [This was done, and the locomotive is presently on exhibition at Carcross Y.T.]. Also described was an excursion, by regular train to Sixteen Island Lake and return.

The final item was a wish from the executive to all the members for a Merry Christmas and a Happy New Year for 1941. The publication then ceased for almost nine years.

The CRHA survived the war, but just barely. Most railway enthusiasts' activities were curtailed, and photographing railway installations was prohibited. Because so many members were serving in the war, membership dropped drastically. The return of peace in 1945 saw a very different CRHA from that of the thirties. Gradually, however, it was rebuilt and new members soon raised the membership numbers above the previous highs. The 100th anniversary of the Montreal & Lachine Railway in 1947 increased the interest in railway history. By 1949 it was felt that it was time to have a new publication and, in October 1949, the "C.R.H.A. News Report" was born. Except for a five month hiatus from September 1951 to January 1952, and with a name change in 1962, this has continued to the present time. At first the publication bore no number, only the date, but in January 1954 it was decided to number each issue retroactively from No. 1 in October 1949; thus January 1954 became No. 41. Unfortunately, for some reason, the rebirth of the publication was considered to have been its beginning, and this spoiled the continuity with the original Bulletin. Had this continuity been observed, as it should have been, October 1949 would have been No. 16, and the present issue would have been No. 473. The continuity with the old Bulletin was not entirely lost. The "Bulletin" series was reserved for monographs and larger works and, in fact Bulletins Nos. 16, 17, 18 and 19 actually did appear in the 1950s and early '60s. It is entirely possible that more bulletins will appear in the future, so the old series still continues.

The CRHA News Report continued to evolve and improve. Soon photographs appeared and, starting in January 1961, a smaller but thicker format was adopted. Starting with issue No. 135, July-August 1962, the name was changed to Canadian Rail. The small format was used for 22 years, then, starting with No. 372, January-

The BULLETIN of the
CANADIAN RAILROAD HISTORICAL ASSOCIATION
Chateau de Ramezay, Montreal. No. 1. April, 1937.

FOREWORD.

In presenting this, the first number of its official journal, the Canadian Railroad Historical Association realizes in a modest way the ambition of its members since its foundation.

The ultimate purpose of this publication is to accumulate gradually in one compendium the records of Canadian railway development. We propose that in future it will be a source of reference for those who, like ourselves, will be interested to know the circumstances attending this most important national institution from its inception to its culmination in the achievements of the present day.

We aim to distribute the work of gathering information among many, by giving to each a particular field in which to prosecute research. Herein lies a hidden advantage which our members are asked to discern. It is a certainty that in pursuing the study of their chosen subject they will discover material not in their department, but of interest to a fellow worker. In all such cases the endeavor should be to transmit such information to its proper department, and by following such a system of reciprocal exchange of historical material between members, we shall soon possess records covering every phase of Canadian railway history.

During the five years of our Association's existence, we have not confined ourselves strictly to railway history. It is only natural that in the minds which form our circle, there should be a deep and engaging interest in all that appertains to the development of steam, internal-combustion, and electrical transportation, whether on land or water, and as consequence, we have adopted the study and record of steamship, steamboat, and street-car history, and we propose to embrace the evolution of aerial transport as well.

Our ambition is as great as the field before us, but our enthusiasm is proof against discouragement. The Association is one for recreative study, where we may pursue at leisure our selected theme with assurance of success. For, no matter how small may be our contribution, the little we will contribute will be a coin in the collection that is surely destined to be a treasure of record in the days to come.

The President.

The first page of the first issue.

February 1983 the large size was begun and the frequency was reduced to six times a year. A few issues with colour covers have been produced, and it is hoped that this will be done again in the future. The latest change occurred with No. 456, January 1997, when the slightly larger standard size of 8" by 11 inches was adopted.

From the original typewriter and mimeograph of sixty years ago to the Pentium computer of today is a long way. However the basic "raison d'etre" of the publication remains the same, and the original statement on page 1 of issue No. 1 can not be improved upon. In 1997, as in 1937, it is the members that we depend upon for the success of the publication, and of the Association. All Aboard for the next Sixty Years!

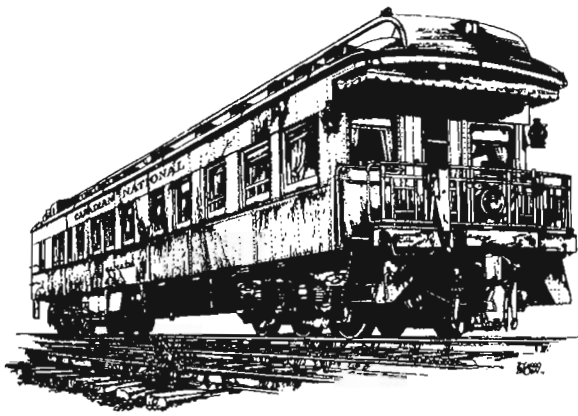

The Business Car

MORE COMMENTS RE. CHARLES M. HAYS

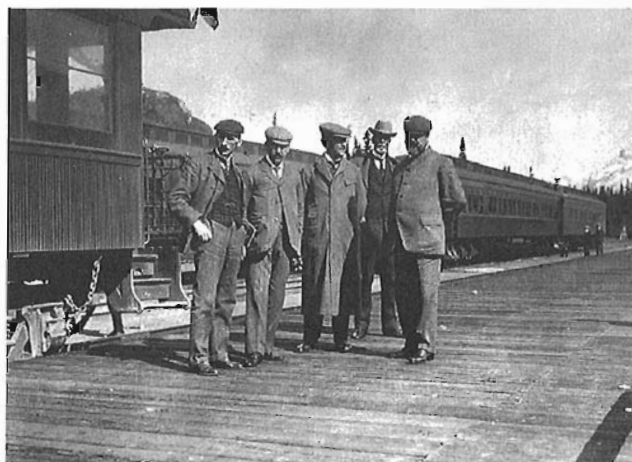

National Archives of Canada PA-21904

MORE OBSERVATIONS ON THE PENNY WRECK

Mr. W.E. Ottewell of Revelstoke B.C., under date of April 16, 1997, writes:

Have just finished reading your article on the Penny Wreck, it was very interesting, I had never heard of it way out here.

As to why the train left the track at that particular spot, could I offer a possible reason? In the handling of steam powered trains, the engineers usually did the same things at the same time and place every trip. When releasing the brake on a descending grade after the last reduction of the brake pipe is made, you must time the release so you can start working steam to run away from the train to avoid a run in of the slack.

In order to get run in or run out, one part of the train has to be going faster or slower than the other. A steam engine with all its motion going around will run slower than the train on a descending grade. This will only happen on engines that have relief valves on their cylinders, as these allow you to run down hill with the steam to cylinders shut off.

If the engine were not equipped with relief valves, the engineer would have to work light steam down grade so would not as likely get the run in. Most CP engines had relief valves, most CN engines did not. As we do not have a photo of the locomotive in question will have to leave it at that.

It is interesting to note on the top photo on page 476 all the journal box lids seem to be open. They look like conventional lift box lids, while the ones on the car below have the older style swing lids.

It is also interesting that the C.P. and Intercolonial timetable shown on page 4 has the time in the 24 hour system. The eastern lines usually used AM and PM.

CONGRATULATIONS TO PRO-CEL

The firm that prints Canadian Rail, Pro-Cel Printing, has just completed 40 years of operation. Founded in 1957 by Mr. Albert Mercantini, the firm was run by him until his death in 1994. Since then it has been run by his daughter Carmen. Pro-Cel has been printing Canadian Rail, and its predecessor the CRHA News Report, since 1960, which was not long after the publication changed to offset printing from the old mimeograph process. So we have been customers of Pro-Cel for 37 of the 40 years the firm has been in existence.

At this significant anniversary we congratulate Pro-Cel and hope that our relationship will continue for many more years.

Several members have pointed out that the photo showing Mr. Hays on an inspection trip (cover of Issue No. 454, November-December 1996, but reproduced above) was likely taken at Banff Alberta and not Jasper as surmised. Since the Grand Trunk Pacific was not completed in Mr. Hays' time, it stands to reason that the inspection party would travel to the west coast on the CPR. The background scenery appears like Banff, and one of the cars shown almost certainly is an 1886 CP sleeping car of the "Yokohama" class. These 12-section 1-drawing room cars are distinguished by the two large windows, approximately midway on each side, which is where the sofa sections are located.

ANOTHER RARE STAMP?



We have received a letter, dated April 1, 1997, from Mr. Jack Point commenting on our recent article on stamps depicting railway subjects:

"I would like to draw your attention to the following very rare stamp. When the first decimal stamps of New Brunswick were

being prepared, the engraver had never seen a locomotive so he did not know which way was up. He thereupon engraved the locomotive the way he had received the photograph, which unfortunately happened to be upside down. Only one of these stamps was ever printed; it was issued on April 1, 1860 and was immediately stuck on a letter and mailed to a house only half a mile away. It took exactly 137 years to be delivered, which is even longer than it sometimes takes Canadian Rail to arrive! However it finally arrived this morning, just in time for me to send you an illustration of it".

Editor's note: Before you rush out looking for another one of these stamps, or sell your Bre-X stock trying to pay for it, please note the date of Mr. Point's letter, as well as the date of the alleged issue of this stamp. Also we point out (pun intended) that Jack Point was the name of the jester in Gilbert and Sullivan's operetta *The Yeomen of the Guard*!

LE TORTILLARD EST MORT, VIVE LE P'TIT TRAIN DE CHARLEVOIX!

Un nouveau train touristique reliera Québec et La Malbaie dès le 27 juin. Le p'tit train de Charlevoix prendra en quelque sorte la relève du Tortillard du Saint-Laurent qui a rendu l'âme au cours de l'hiver après une fin de saison en que de poisson.

Le p'tit train de Charlevoix partira de la chute Montmorency à 8h. M. Ovide Morin, un ex-directeur du train touristique, croit que le trajet plus court et des locomotives plus performantes permettront de raccourcir le trajet de 40 minutes à l'aller et autant au retour. "C'est une heure trente de plus dans Charlevoix que nous pourrions offrir à nos clients" fait-il observer.

Le Soleil, Québec, le 16 Avril, 1997.

MONAD, NOT NOMAD

Mr. L.S. Kozma of Edmonton, Alberta, writes: I wish to point out a small typographical error on page 169 of Canadian Rail No. 455, November-December 1996. Of course, the Northern Pacific (NP) logo incorporated a "MONAD", not a nomad as noted in the text (so much for the spell checker??!!).

There is an interesting, if somewhat tenuous, connection between this NP logo and Canadian railroading. Edwin Harrison McHenry is generally credited with importing the monad from the Far East. Mr. McHenry was born in 1859 in Cincinnati, Ohio, graduating from the Pennsylvania Military College in Chester Pennsylvania. He began his railway career with the Northern Pacific Railroad in 1883 as a rodman on the Black Hills branch. Within a decade he had worked his way up to the position of Chief Engineer of the road. In 1896 he was appointed Receiver for the line, and upon its reorganization he re-assumed the position of Chief Engineer. Mr. McHenry had an obvious affection for Asia. He resigned from the NP in 1901 and spent the next two years in the Far East. The monad was obviously incorporated into the NP logo prior to this time.

In 1903 he joined the CPR as Chief Engineer. Most of the CPR's building plans of this era bear his signature. Many of these standards were still employed decades after he left the CPR. He resigned in October 1904 after accepting the position of Vice President of the Consolidated Railway, in charge of construction, operation and maintenance of the New York New Haven & Hartford Railroad. He was also in charge of the construction and maintenance departments of the Boston and Maine Railroad. While Chief Engineer of the Northern Pacific, he developed the "McHenry" mechanical coaling plant, variants of which were later used by the CPR and CNoR.

BOOK ABOUT HARRY BRAITHWAIT ABBOTT

Harry Braithwaite Abbott was the younger brother of Sir John Abbott, the first Canadian-born Prime Minister. Both John and Harry were deeply involved in the planning and completion of the CPR. This biography of H.B. Abbott was written about 1920 by his son James L.G. Abbott, LL.B., a Vancouver lawyer, and was reprinted by Elizabeth Abbott in 1996. It contains 100 pages in a simple soft cover; its usefulness and value to the lover of history is that it contains anecdotes on early Canadian fishing and hunting, railroad, political and social life, leading up to the driving of the Last Spike, at which H.B.A. was present. It also describes British Columbia's early years as a province of Canada, and Vancouver in its infancy. The first-hand observations of Harry's son include com-



ments on famous political and business figures of the times, such as Sir William Van Horne and Lord Shaughnessy, giving snatches of insight into their character.

Harry B. Abbott has in recent years been recognized not only for his railway work but for his contribution to early B.C. life. He is considered by the Canadian Museum of Man to be an important early B.C. painter, and his old home at 720 Jervis Street, Vancouver has become the centre of a large heritage project under the auspices of Commonwealth Historic Resource Management Ltd. Here Abbott lived with his wife Amélie Sicotte, daughter of l'Honourable Juge Louis Victor Sicotte of Montreal and St-Hyacinthe, Que., Joint Premier of United Canada in the Macdonald - Sicotte administration of 1862-63.

For a copy of this most interesting book, please send \$14.00 (postpaid) to:

Elizabeth Abbott
10 Rue Legault
Ste. Anne de Bellevue, Que.
H9X 1Z2

CANADIAN NATIONAL RAILWAY AND PARTNERS' PLAN

CN and its alliance partners, New York Susquehanna and Western, New York & Atlantic (which has taken over the Long Island Rail Road's freight operations), and Buffalo & Pittsburgh R.R. are seeking State of New York support for their proposed network. The alliance said their plan to enhance rail competition for north-east U.S. shippers would entail estimated investments of almost \$60 million for track improvements and new terminals.

CN's executive vice-president Gerald Davies said the dismemberment of Conrail by NS and CSX puts at risk two New York State rail lines - the Montreal - Syracuse or "Massena" route, and the Southern Tier line linking the New York City area and Buffalo. Both lines are thinly-trafficked and are unlikely to draw sustained new investment by either CSX or NS. This would undermine the viability of the lines and threaten shippers and rail employees alike. Canadian freight now moving over the Massena line generates two trains daily and accounts for 80% of the route's traffic base.

Source: The 470.

Canadian Rail

120, rue St-Pierre, St. Constant, Québec
Canada J5A 2G9

Postmaster: if undelivered within
10 days return to sender, postage guaranteed.

BULLETIN OF THE CANADIAN RAILROAD HISTORICAL ASSOCIATION



OUR FIRST MASTHEAD
SIXTIETH ANNIVERSARY OF C.R.H.A. PUBLICATIONS
1937 - 1997